



# Cat<sup>®</sup> Compactors

BACKHOE LOADERS

HYDRAULIC EXCAVATORS

MINI-HYDRAULIC EXCAVATORS, SKID STEER LOADERS

## FEATURES:

### Superior compaction force

- These units produce high-power impulses at a rate of 2200 impacts per minute driving soil particles close together for solid, stable compactions.

### Quality components

- A heavy-duty steel frame and solid rubber bushing deliver the maximum amount of power to the ground while minimizing machine impact.
- Vibration driven by a high-efficiency motor for consistently reliable power.
- Oil-bath bearings and integral hydraulic flow control valve protect the compactor motor from potentially damaging conditions.

### Performance-matched

- Cat Compactors are performance-matched to Cat machines and integrate closely with the Cat Hammer line. Brackets and hydraulic kits are interchangeable between hammers and compactors. Compactors can be used with Pin Grabber Couplers, Dedicated Hydraulic Couplers or Pin Lock Couplers.

- Four sizes are available to match with Cat Backhoe Loaders, Hydraulic Excavators and Mini-Hydraulic Excavators.

### Other Features:

- Hardened steel shaft bearings operate in a continued oil bath. Bearing reliability is second to none; and there is no need for daily greasing.
- Hydraulic hoses are protected inside the frame of the compactor. Jumper lines are routed out the back of the compactor. Hoses are out of the way – even in tight trenches.
- A standard pressure/flow control valve protects the compactor from damaging pressures and flows. One compactor can be used on multiple machines without requiring additional hydraulic adjustment.
- Oil changes are simplified with the rear centerline plug. Oil can be changed while the compactor is installed.
- An optional bolt-on backfill blade can be mounted on both front and back of the compactor.

## Compactor/Backhoe Loader, Hydraulic Excavator, Mini-Hydraulic Excavator, Skid Steer Loader Compatability

Recommended machine matches. Contact your local Cat Dealer for more detailed matching information.

Model	Machines
<b>CVP16</b>	302.5, 302.5CR, 303CR, 303C CR, 303.5C CR, 304CR, 304C CR, 305CR, 305C CR, BH27, BH30, BH150, BH160
<b>CVP40</b>	416, 420, 426, 430, 436, 438, 446, 307, 308CR
<b>CVP75</b>	311, 312, M313, M315, 315, 318, M318
<b>CVP110</b>	312, M320, 320, 324, 325, 330

## Compactor Specifications

Contact your local Cat Dealer for in-depth specifications.

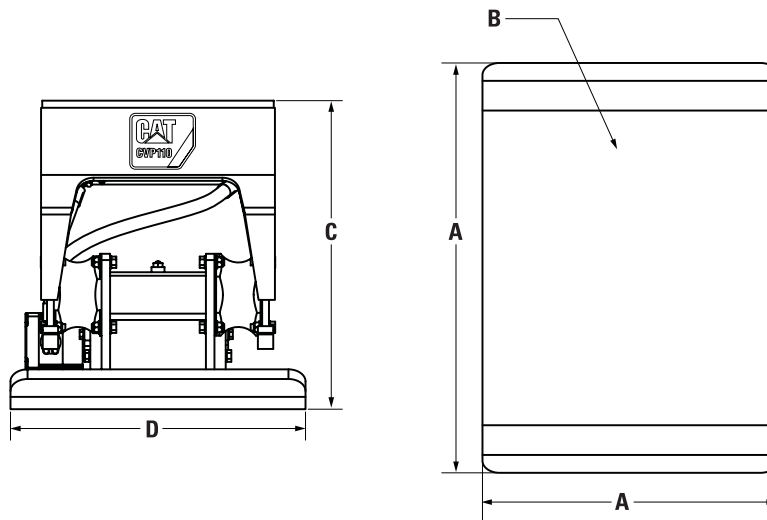

			<b>CVP16</b>		<b>CVP40</b>		<b>CVP75</b>		<b>CVP110</b>	
Weight (without bracket)	kg	(lb)	215	(474)	401	(884)	801	(1765)	1052	(2319)
<b>A</b> Plate Dimensions	mm	(in)	306x610	(12x24)	584x965	(23x38)	737x109	(29x43)	864x1194	(34x47)
<b>B</b> Plate Area	m <sup>2</sup>	(ft <sup>2</sup> )	0.195	(2.1)	0.567	(6.1)	0.799	(8.6)	1.031	(11.1)
<b>C</b> Height	mm	(in)	571	(22.5)	622	(24.5)	770	(30.3)	903.4	(35.5)
<b>D</b> Width	mm	(in)	305	(12)	584	(23)	737	(29)	(864)	(34)
Impulse Force	kN	(lb)	16	(3650)	40	(8928)	75	(16508)	110	(24669)
Impact Frequency	blows/minute		2200		2200		2200		2200	
Base Plate Pressure	kPa	psi	88	(12.76)	70.05	(10.16)	91.91	(13.33)	106.39	(15.43)

For more complete information on Cat products, dealer services, and industry solutions, visit us on the web at [www.cat.com](http://www.cat.com)

GEHQ0181-03 (06-07)

Replaces GEHQ0181-02

©2007 Caterpillar  
All Rights Reserved  
Printed in U.S.A.

Materials and specifications are subject to change without notice. Featured machines in photos may include additional equipment. See your Caterpillar dealer for available options.

CAT, CATERPILLAR, their respective logos, "Caterpillar Yellow," and the POWER EDGE trade dress, as well as corporate and product identity used herein, are trademarks of Caterpillar and may not be used without permission.