

# Cat<sup>®</sup> S Type Couplers

Excavator Couplers

## Technical Specifications

Not all attachments available in all regions. Consult your Cat<sup>®</sup> dealer for specific configurations available in your region.

### Table of Contents

<b>Specifications</b> .....	<b>2</b>
<b>Dimensions</b> .....	<b>3</b>
<b>Matching</b> .....	<b>4</b>
Machine Matching .....	4
Hydromechanical Matching .....	5

# S Type Couplers Technical Specifications

## Specifications

Model	Part Number	Linkage	Carrier Weight, Minimum	Carrier Weight, Maximum	Permitted Positive Torque	Permitted Negative Torque	Weight		Lift Hook Capacity	
			ton	ton	kN·m	kN·m	kg	lb	ton	lb
S60	573-3161	M312	11	19	150	75	174	384	5	10000
	573-3168	312	11	19	150	75	147	324	5	10000
	573-3166	315	11	19	150	75	176	388	5	10000
S70	566-2349	B/M320	16	30	300	195	259	571	8	16000
	566-2351	CB	16	30	300	195	285	628	8	16000
S80	573-3169	CB	25	40	600	390	426	939	10	20000
	573-3171	DB	25	40	600	390	456	1005	10	20000

# S Type Couplers Technical Specifications

## Dimensions

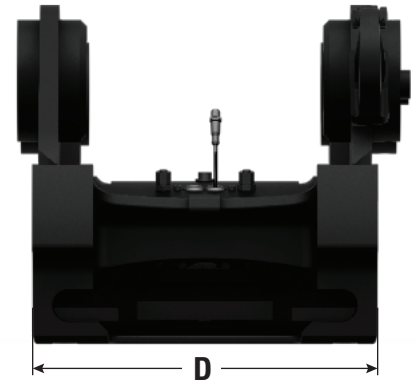
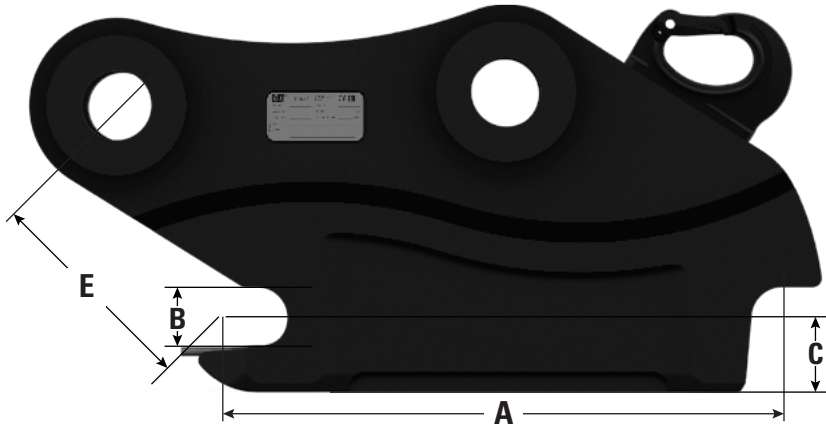

Model	Part Number	(A) Pin to Pin		(B) Shaft Diameter		(C) Height		(D) Width		(E) Hinge Distance	
		mm	in	mm	in	mm	in	mm	in	mm	in
S60	573-3161	480	18.9	60	2.4	75	3.0	340	13.4	245	9.6
	573-3168	480	18.9	60	2.4	75	3.0	340	13.4	225	8.9
	573-3166	480	18.9	60	2.4	75	3.0	340	13.4	235	9.3
S70	566-2349	600	23.6	70	2.8	85	3.3	450	17.7	290	11.4
	566-2351	600	23.6	70	2.8	85	3.3	450	17.7	295	11.6
S80	573-3169	670	26.4	80	3.1	108	4.3	590	23.2	295	11.6
	573-3171	670	26.4	80	3.1	108	4.3	590	23.2	315	12.4

# S Type Couplers Technical Specifications

## Machine Matching

Match

No Match

	S60	S70	S80
<b>Small Excavators</b>			
311F	✓		
313F GC	✓		
313F	✓		
313 GC	✓		
313	✓		
315F	✓		
315	✓		
316F	✓		
318F	✓		
<b>Medium Excavators</b>			
320F		✓	
320 GC		✓	
320		✓	
323F		✓	
323		✓	
325F		✓	
325		✓	
326F		✓	✓
326		✓	✓
330F		✓	✓
330 GC		✓	✓
330		✓	✓
335F		✓	✓
<b>Large Excavators</b>			
336F			✓
336F XE			✓
336 GC			✓
336			✓
340F			✓
340			✓

	S60	S70	S80
<b>Wheeled Excavators</b>			
M314F	✓		
M314	✓		
M315F	✓		
M316F	✓		
M316	✓		
M317F	✓		
M318F	✓		
M318	✓		
M320F		✓	
M320		✓	
M322F		✓	
<b>Material Handlers</b>			
MH3022*		✓	
MH3024*		✓	
MH3026*		✓	

\*when equipped with appropriate stick and bucket linkage

# S Type Couplers Technical Specifications

## Hydromechanical Matching

Check your machine's configuration to determine optimal coupler and attachment combinations.

Match

No Match

Family	Model	S60	S70	S80
Hydraulic Hammers	H110 GC S	✓		
	H110 S	✓		
	H115 GC S	✓		
	H115 S	✓	✓	✓
	H120 GC S		✓	✓
	H120 S	✓	✓	✓
	H130 S	✓	✓	✓
	H140 S		✓	✓
Multi-Processors	MP318 Concrete Cutter Jaw	✓	✓	✓
	MP318 Demolition Jaw	✓	✓	✓
	MP318 Pulverizer Jaw	✓	✓	✓
	MP318 Shear Jaw	✓	✓	✓
	MP318 Universal Jaw	✓	✓	✓
	MP324 Concrete Cutter Jaw		✓	✓
	MP324 Demolition Jaw		✓	✓
	MP324 Pulverizer Jaw		✓	✓
	MP324 Shear Jaw		✓	✓
	MP324 Tank Shear Jaw		✓	✓
	MP324 Universal Jaw		✓	✓
Demolition and Sorting Grapples	G312 GC	✓		
	G313 GC	✓		
	G314	✓		
	G317 GC	✓	✓	✓
	G318	✓	✓	✓
	G318 WH-800	✓	✓	✓
	G318 WH-1100	✓	✓	✓
	G324		✓	✓
	G324 WH-1500		✓	✓
	G324 WH-1800		✓	✓
	G324 WH-2000		✓	✓
	G332		✓	✓
	Mobile Scrap and Demolition Shears	S3015 Flat Top	✓	
S3025 Flat Top			✓	✓
S3035 Flat Top			✓	✓
Pulverizers	P215	✓	✓	✓
	P225		✓	✓
Crushers	P315	✓	✓	✓
	P325		✓	✓
Compactors (Vibratory Plate)	CVP75	✓	✓	✓
	CVP110		✓	✓

For more complete information on Cat products, dealer services, and industry solutions, visit us on the web at [www.cat.com](http://www.cat.com)

© 2020 Caterpillar  
All rights reserved

Materials and specifications are subject to change without notice. Featured machines in photos may include additional equipment. See your Cat dealer for available options.

CAT, CATERPILLAR, LET'S DO THE WORK, their respective logos, "Caterpillar Corporate Yellow," the "Power Edge" and Cat "Modern Hex" trade dress as well as corporate and product identity used herein, are trademarks of Caterpillar and may not be used without permission.

GEJQ9382-01 (10-2020)  
Replaces GEJQ9382-00  
(EU, N Am, S Am)

