

Shown with
Optional Equipment

FEATURES



EMISSIONS

- Meets most worldwide emissions requirements down to 250 mg/N•m³ NO_x level without after treatment

FULL RANGE OF ATTACHMENTS

- Wide range of bolt-on system expansion attachments, factory designed and tested

SINGLE-SOURCE SUPPLIER

- **Fully Prototype Tested** with certified torsional vibration analysis available

WORLDWIDE PRODUCT SUPPORT

- With over 1,800 dealer branch stores operating in 166 countries, you're never far from the Caterpillar part you need.
- 99.5% of parts orders filled within 48 hours. The best product support record in the industry.
- Caterpillar dealer service technicians are trained to service every aspect of your electric power generation system.
- Customer Support Agreements offer back-to-back services from scheduled inspections and preventive maintenance to before-failure overhauls and Total Cost-Per-Hour Guarantees.

CONTINUOUS

1356 kVA

1431 kVA

50 Hz

Caterpillar is leading the power generation marketplace with Power Solutions engineered to deliver unmatched flexibility, expandability, reliability, and cost-effectiveness.



CAT® G3516B LE GAS ENGINE

- Robust design provides prolonged life and lower owning and operating costs
- Designed for maximum performance on low pressure pipeline natural gas
- One electronic control module handles all engine functions: ignition, governing, air fuel ratio control, and engine protection



CAT SR4B GENERATOR

- Designed to match performance and output characteristics of Caterpillar engines
- Optimum winding pitch for minimum total harmonic distortion and maximum efficiency
- Segregated low voltage (AC/DC) accessory box provides single point access to accessory connections



CAT CONTROL PANELS

- Designed to meet individual customer needs: EMCP II+ provides full-featured power metering, purge cycle, staged shutdown logic, plus programmable protective relaying functions
- Remote control and monitor capability options

LEHE1883

FACTORY INSTALLED STANDARD & OPTIONAL EQUIPMENT

System	Standard	Optional
Air Inlet	Modular air cleaner, single element service indicator	
Cooling	Engine driven water pumps for jacket water and aftercooler circuit, jacket water and SCAC thermostats Cat flange connections	
Engine Control Module	Fuel/air ratio control Start/stop logic: gas purge cycle, stage shutdown Engine Protection Systems: detonation sensitive timing, high jacket water temperature, low oil pressure, failure to start (overcrank), overspeed, high oil temperature, emergency stop, transient richening and turbo bypass control	
Exhaust	Dry exhaust manifolds Cat flanged outlet	15 dBA muffler 18 dBA muffler Spark arresting muffler without companion flanges
Fuel	Electronic air fuel ratio control (Engine Control Module; ADEM III based), electronic fuel metering valve, gas shutoff valve, 24 volt energized-to-run	Fuel filter (non-coalescent) Gas train with 24V double gas shutoff valve, isolation valve, regulator, gas leak detection
Ignition	Electronic ignition system, individual cylinder timing and detonation control	
Integrated Thermo Sensing Module (ITSM)	24 thermocouples to input individual exhaust port temperatures and turbo inlet and outlet temperatures on both the turbine and compressor	CCM transfers Cat DataLink information through RS232 to customer terminal
Generator	Permanent magnet excitation, 105° C rise, single bearing, form wound, six lead, 3-phase sensing, platinum stator RTDs, class H Insulation, DVR with adjustable 1:1 or 2:1 Volts/Hz, bus bar termination, extension box, segregated low voltage wiring panel	Digital Voltage Regulator with KVAR/PF control oversize and premium generators, circuit breaker, IEC compliant, 3-pole and 4-pole, bearing temperature detector low voltage cable extension box
Governor	Electronic - Engine Control Module	Electronic load sharing (ship loose module)
Control Panels	EMCP II+	Local alarm and remote annunciator modules Customer Interface Module, synchronizing module
Lube	Lubricating oil and filter, oil drain valve crankcase breathers gear type lube oil pump, integral lube oil cooler, filler/dipstick	Closed crankcase ventilation system, prelube pump
Mounting	Spring-type anti-vibration isolators	
Starting/Charging	60 amp charging alternator Dual 24 volt starting motor Batteries with rack and cables Batteries disconnect switch	Battery charger, air starting system, jacket water heaters, 12 kW (dual 6 kW) 400 V/3 phase/50 Hz heater element; 9 kW 400 V/3 phase 50 Hz with 200V/1 phase/50 Hz circulation pump, battery disconnects switch, oversize batteries
Other		EEC Declaration of Incorporation

SPECIFICATIONS



CAT SR4B GENERATOR

Frame size	824
Excitation	Permanent magnet
Pitch	0.6667
Number of poles	4
Number of bearings	1
Number of leads	6
Insulation	UL 1446 Recognized Class H Insulation
IP rating	Drip proof IP22
Alignment	Pilot shaft
Overspeed capability	125%
Wave form	Less than 5% deviation
Paralleling kit droop transformer	Standard
Voltage regulator	3-phase sensing with adjustable 1:1 or 2:1 Volts/Hz, UL 508A Listed
TIF	Less than 50
THD	Less than 3%

Consult your Caterpillar dealer for available voltages.



CAT ENGINE

G3516B SCAC, 4-Stroke-Cycle Watercooled Gas	
Bore — mm (in)	170 (6.7)
Stroke — mm (in)	190 (7.5)
Displacement — L (cu in)	69 (4210)
Compression ratio	11.7:1
Aspiration	Turbocharged, Separate Circuit Aftercooled
Fuel system	Electronic Ignition System
Governor type	Electronic Engine Control Module



CAT CONTROL PANEL

- 24 Volt DC Control
- NEMA 1, IP22 enclosure
- Electrically dead front
- Lockable hinged door
- Generator instruments meet ANSI C-39-1
- Terminal box mounted
- Single location customer connector point
- EC compliant — segregated AC/DC connections and wiring

TECHNICAL DATA

Generator Set — 1500 rpm/50 Hz/400 Volts		DM5490	DM5492	DM5489	DM5491
G3516B LE Gas Generator Set					
Emission Level (NO _x)	mg/N•m ³	250	250	500	500
Aftercooler, two stage (JW in/SCAC)	Deg C	92/54	92/32	92/54	92/32
Package Performance (1)					
Power rating @ 1.0 pf (unity)	ekW	1100	1160	1100	1160
Power rating @ 0.9 pf	ekW	1095	1155	1095	1155
Power rating @ 0.8 pf (3)	ekW	1085	1145	1085	1145
	kVA	1356	1431	1356	1431
Fuel Consumption (2)					
Electrical Efficiency @ 1.0 pf	%	36.4	38.0	37.9	39.1
100% load with fan	N•m ³ /hr	306	310	294	301
75% load with fan	N•m ³ /hr	241	243	232	237
50% load with fan	N•m ³ /hr	172	173	166	171
Altitude Capability (3)					
At 25° C ambient	m	375	255	450	280
Cooling System					
Jacket water temperature (maximum outlet)	Deg C	99	99	99	99
Exhaust System					
Combustion air inlet flow rate	N•m ³ /min	93	96	88	93
Exhaust stack gas temperature	Deg C	516	485	526	486
Exhaust gas flow rate	N•m ³ /min	100	103	94	99
Exhaust flange size (internal diameter)	mm	305	305	305	305
Heat Rejection (4)					
Low Heat Value (LHV) fuel input	kW	3107	3140	2988	3056
Heat rejection to jacket water (includes JW, oil cooler, and A/C — Stage 1)	kW	624	610	596	586
Heat rejection to A/C — Stage 2	kW	79	123	73	117
Heat rejection to atmosphere	kW	100	100	100	100
Heat rejection to exhaust (LHV to 120° C)	kW	921	871	896	842
Heat rejection to atmosphere from generator	kW	33	35	33	35
Alternator					
Motor starting capability @ 30% voltage dip*	kVA	2551	2551	2551	2551
Frame		824	824	824	824
Temperature rise	Deg C	90	90	90	90
Lube System					
Lube oil refill volume w/filter change for std sump	L	401	401	401	401
Emissions**					
NO _x	mg/N•m ³ @ 5% O ₂	250	250	500	500
CO	mg/N•m ³ @ 5% O ₂	940	1014	1083	1105
HC (total)	mg/N•m ³ @ 5% O ₂	2267	2868	2076	2433
HC (non-methane)	mg/N•m ³ @ 5% O ₂	341	431	312	365
Exhaust O ₂ (dry)	%	9.0	9.8	9.3	9.9

*Assumes synchronous driver.

**Emissions data measurements are consistent with those described in EPA CFR 40 Part 89 Subpart D & E and ISO8178-1 for measuring HC, CO, PM, NO_x. Data shown is based on steady state engine operating conditions of 25° C (77° F), 96.28 kPa (28.43 in Hg) and fuel having an LHV of 35.6 mJ/N•m³ (905 Btu/cu ft) at 101.60 kPa (30.00 in Hg) absolute and 0° C (32° F). Not to exceed emission data shown is subject to instrumentation, measurement, facility and engine fuel system adjustments.

RATING DEFINITIONS AND CONDITIONS

Continuous — Output available without varying load for an unlimited time.

(1) Ratings are based on pipeline natural gas having a LHV (low heat value) of 35.6 mH/N•m³ (905 Btu/cu.ft) and 90 MN. For values in excess of the altitude, temperature, inlet/exhaust restriction, or for natural gas composition different from the conditions listed, contact your local Caterpillar dealer.

(2) Ratings and fuel consumption are based on ISO3046/1 standard reference conditions of 25° C (77° F) and 100 kPa (29.61 in Hg.) with 0,+5% fuel tolerance.

(3) Altitude capability is based on 2.5 kPa inlet and 5.0 kPa exhaust restriction.

(4) Heat Rejection — values based and ISO3046/1 with fuel tolerance of + or -3% and 2.5 kPa inlet and 5.0 kPa exhaust restriction.

CONTINUOUS POWER GENERATOR SET PACKAGE — TOP VIEW

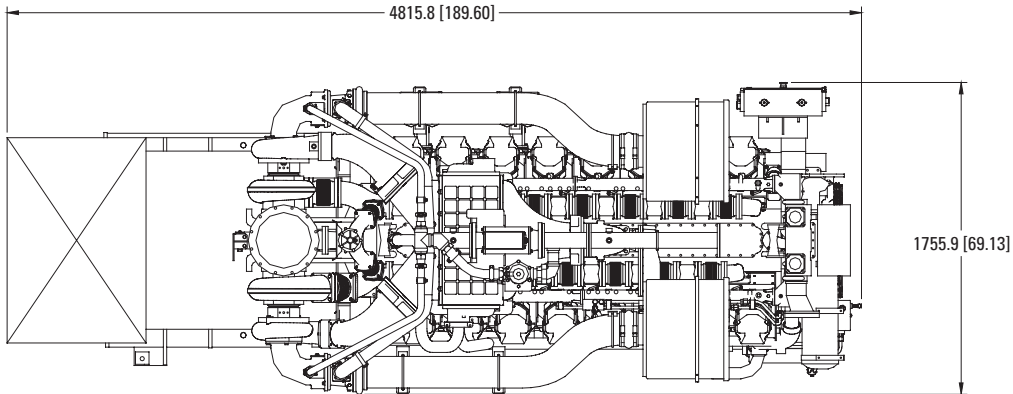

CONTINUOUS POWER GENERATOR SET PACKAGE — SIDE VIEW

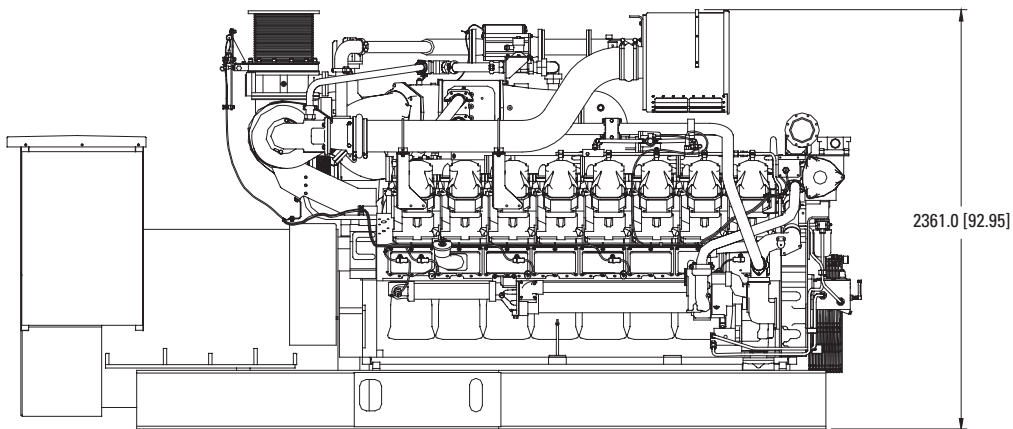

Package Dimensions		
Length	4815.8 mm	189.60 in
Width	1755.9 mm	69.13 in
Height	2361.0 mm	92.95 in
Shipping Weight	12 809 kg	28,239 lb

Note: Do not use for installation design.
See general dimension drawings
for detail (Drawing #212-9994).