

Landscape Rakes

for Skid Steer, Multi Terrain, Compact Track and Compact Wheel Loaders



*Landscape rakes are used to sieve soil and remove stones prior to sowing grass.
Can be used in conjunction with Caterpillar Landscape Tillers.*

Features

- 'Bolt-on' conveyor assembly tubes
- Robust front hood
- Hydraulic relief valve
- 'Sprocket and Idler' placement
- Hydraulic driven open/close hood

Benefits

- Easy replacement of the entire conveyor assembly.
- Increased durability when turning, loading and opening/closing the conveyor system.
- Conveyor assembly from being damaged if an object becomes lodged in the unit.
- Improved balance, resulting in superior surface finish.
- Easy discharge of collected debris.

LR15B, LR18B Landscape Rakes

Specifications and Dimensions

| | | LR15B | LR18B |
|--|-----------------|---------|---------|
| A Overall Width | mm | 1683 | 1990 |
| B Working Width | mm | 1576 | 1883 |
| C Raking Width | mm | 1384 | 1655 |
| D Overall Length | mm | 1620 | 1620 |
| E Overall Height | mm | 989 | 989 |
| Unit Weight | kg | 595 | 653 |
| Bucket Capacity (struck)* | m ³ | 0.31 | 0.34 |
| Drive Method | | | |
| Single Uni-directional Gerotor Motor – chain | | | |
| Required Hydraulic Flow | L/min | 42-83 | 42-83 |
| Optimal Hydraulic Pressure | bar | 235 | 235 |
| Effective Displacement | cm ³ | 315 | 315 |
| Drive Shaft Speed at 80 Lpm | rpm | 165 | 165 |
| Torque at 230 bar | Nm | 1774 | 1774 |
| Fasteners | | Cat | Cat |
| Hydraulic Hose | Cat | XT-3 ES | XT-3 ES |
| Number of Hard-faced Tines | | 372 | 444 |
| Rock Size max. | mm | 150 | 150 |

* Rated struck capacities shown as per ISO 7546:1983.

Theoretical values calculated at 100% efficiency.

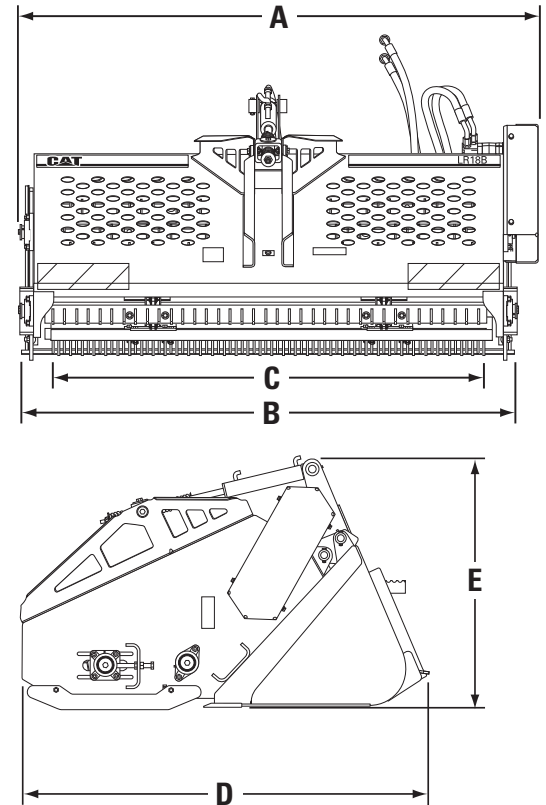

Hydraulic Requirements

Standard flow hydraulics and no electrics.

Matching Guide

| Rakes | Skid Steer Loaders | Multi Terrain Loaders | Compact Track Loaders |
|-------|--|------------------------------|-----------------------|
| LR15B | 216B, 226B, 232B, 242B, 236B, 252B, 246C, 256C, 262C, 272C | 247B, 257B, 277C, 287C, 297C | 279C, 289C, 299C |
| LR18B | 236B, 252B, 246C, 256C, 262C, 272C | 247B, 257B, 277C, 287C, 297C | 279C, 289C, 299C |
| | Compact Wheel Loaders | | |
| LR15B | 906H, 907H, 908H | | |
| LR18B | 906H, 907H, 908H | | |

For more complete information on Cat products, dealer services, and industry solutions, visit us on the web at www.cat.com

HEHX3176-3 (10/2008) hr

© 2008 Caterpillar -- All Rights Reserved

Materials and specifications are subject to change without notice. Featured machines in photos may include additional equipment. See your Caterpillar dealer for available options.

CAT, CATERPILLAR, their respective logos, "Caterpillar Yellow" and the POWER EDGE™ trade dress, as well as corporate and product identity used herein, are trademarks of Caterpillar and may not be used without permission.

CATERPILLAR[®]
TODAY'S WORK. TOMORROW'S WORLD.™