

# C8.7

## MARINE PROPULSION ENGINE

478 bkW (641 bhp) @ 2300 rpm

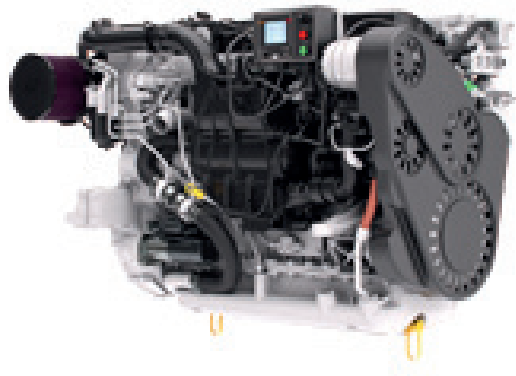

C8.7 Marine Propulsion Engine  
U.S. EPA Tier 3 / IMO II

### ENGINE SPECIFICATIONS

#### Configuration

In-line 6, 4-Stroke-Cycle-Diesel

#### Emissions

Recreational:  
U.S. EPA Tier 3 (E5 Cycle - Recreational only), IMO II (EPA, GL and SeeBG), Recreational Craft Directive (EU) RCD  
Commercial:  
EU Stage IIIA, IMO II (GL and SeeBG), CCNR Stage II through reciprocity with EU Stage IIIA

#### Rated Engine Speed

2300 rpm

#### Bore x Stroke

117 mm x 135 mm  
4.6 in x 5.3 in

#### Displacement

8.7 Liter  
531 cu in

#### Aspiration

Turbocharged, supercharged, aftercooled aspiration

#### Governor

Electronic

#### Refill Capacity

Lube oil system w/ oil filter change:  
34 L (8.8 gal)  
Coolant capacity  
41 L/10.6 Gal

#### Oil Change Interval

250 hrs

#### Cooling

Heat exchanger cooled

#### Flywheel Housing

SAE No. 1 with SAE No. 14  
Flywheel (149 teeth)

#### Rotation

Counterclockwise from flywheel end

### FEATURES AND BENEFITS

- Electronically controlled supercharger provides industry-leading torque and throttle response at low speeds, while maintaining fuel efficiency at high speeds
- Closed crankcase ventilation system improves engine room cleanliness
- Common rail fuel system enables optimum combustion and low emissions
- Single access point improves serviceability
- Grid heater for improved cold weather starting
- Compatible with Cat Marine Displays
- Available engine-mounted display panel with start, stop, and engine diagnostics
- 12V or 24V electrical system
- gplink ready for remote monitoring

### STANDARD ENGINE EQUIPMENT

- Watercooled turbocharger and exhaust manifold
- Electronically controlled supercharger
- Closed crankcase ventilation system
- Thermostats and housing
- Gear-driven sea water pump (bronze impeller)
- Common rail fuel system
- Shell and tube type jacket water heat exchanger
- Corrosion resistant sea water aftercooler
- Fuel cooler
- Engine oil cooler
- Vibration damper and guard
- Grid heater
- Electric fuel priming pump

### OPTIONAL ATTACHMENTS

- Alternators
  - – 24V 120 amp
  - – 12V 200 amp
- Transmission gear oil cooler (engine mounted)
- Additional engine and transmission sensor packages for on or off vessel monitoring
- Instrument panels
- Starting motors – 12V or 24V

### E-RATING (HIGH PERFORMANCE) DEFINITION

**Typical applications:** For vessels operating at rated load and rated speed up to 8% of the time, or 1/2 hour out of 6, (up to 30% load factor). Typical applications could include but are not limited to vessels such as pleasure craft, harbor patrol boats, harbor master boats, some fishing or patrol boats. Typical operation ranges from 250 to 1000 hours per year.

**BUILT FOR IT.™**



# TECHNICAL DATA

## C8.7 Marine Propulsion Engine

### PROP DEMAND FUEL CONSUMPTION

rpm	Brake Specific Fuel Consumption			
	bhp	lb/bhp-hr	bkW	g/bkW-hr
2300	641	32.7	478	217.1
2000	422	21.4	315	216.3
1500	178	9.7	133	231.6
1300	116	6.1	86	224.8
950	45	2.4	34	228.4
700	18	1.1	14	261.8

- ISO 3046/1 fluid consumption tolerance of -0/+5%

Note:

Please reference TMI Web for most current information (Cat dealers only)  
Consult your local Cat dealer to create a customized engine TCO (Total Cost of Ownership) analysis specific to your vessel.

### DIMENSIONS & WEIGHT

	Length	Height	Width	Engine dry weight
min.	1218.0 mm/47.9 in	984 mm/38.7 in	881 mm/34.7 in	1041 kg/2295 lb
max.	1850.4 mm/72.9 in			

Note:  
Do not use these dimensions for installation design. See general dimension drawings for detail.

### Cat Three60 Pod 650

**Cat Three60 Pod 650** is an integrated marine maneuvering system designed to be installed and coupled with Cat C8.7 E-rated marine propulsion high performance diesel engine; providing unmatched response and performance.

Rated engine power: 478 bkW, 641 bhp (650 mph)

Rated engine speed: 2300 rpm

Three60 Pod 650 rated torque: 2332 N•m @ 1700 rpm

Three60 Pod 650 rated speed: 2300 rpm

Transmission gear ratio: 2.17:1

Reference LEDM0032 for more information.

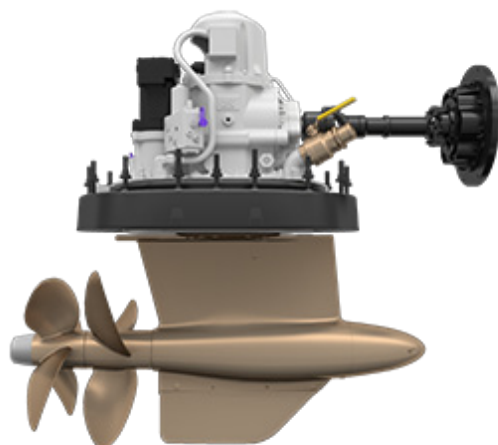

CAT, CATERPILLAR, their respective logos, "Caterpillar Yellow" and the "Power Edge" trade dress, as well as corporate and product identity used herein, are trademarks of Caterpillar and may not be used without permission. U.S. Sourced

LEHM0070-03

To find your nearest dealer, please visit: [www.cat.com/marine](http://www.cat.com/marine)

©2017 Caterpillar  
All rights reserved.

Materials and specifications are subject to change without notice.  
The International System of Units (SI) is used in this publication.