



345C L

Ultra-high Demolition

**CAT**[®]

Cat[®] C13 Diesel Engine with ACERT[™] Technology

Net Power (ISO 9249) at 1800 rpm

239 kW/325 hp

Operating Weight (UHD configurations)

57 870-67 020 kg

Maximum Pin Height

26.1 or 27.9 m

345C L Ultra-high Demolition

Heavy-Duty and purpose built for your demolition job.

Upper Frame and Counterweight

The heavy-duty upper frame handles increased loads and movements. Additional counterweight provides maximum stability throughout the recommended working range.

Booms, Sticks and Work Tools

The 345C L Ultra-high demolition is equipped with a reliable and safe boom hook system that significantly reduces the time needed to change the front parts, providing increased uptime, production and versatility. To further increase the machine's versatility, a short two position retrofit boom nose and demolition sticks are available. To complete the machine, purposely designed Caterpillar work tools are available.

Undercarriage

The 345C L variable gauge undercarriage is stable, durable and has low maintenance. A heavy duty hydraulic variable gauge undercarriage is available as an option, as well as an Extreme Service configuration (365C L undercarriage components).

Operator Station

The safe, roomy, quiet, automatically climate controlled tiltable cab has excellent sightlines to the work tool to help keep operator fatigue low and production up throughout the entire shift.

ADEM™ A4 Electronic Control System

Maximizes fuel efficiency and performance by maintaining the optimum balance between engine speed and hydraulic demand.

Serviceability

Longer service intervals and easier maintenance result in better machine availability and lower owning and operating costs.

Complete Customer Service

Your Cat dealer offers a wide range of services that can be set up under a customer support agreement when you purchase your equipment. The dealer will help you choose a plan that can cover everything from machine and attachment selection to replacement.



Undercarriage

Durable undercarriage absorbs stresses and provides excellent stability.

L Undercarriage. The long undercarriage provides a stable and rugged working platform for demolition.

Optional Hydraulic Variable Gauge Undercarriage. The optional hydraulic variable gauge undercarriage further increases the stability by increasing the track gauge and lowering the center of gravity of the machine, resulting in the usage of a bigger tool. The non-bolt joint allows changing from shipping to working width or reverse in less than one minute. Shipping width 3000 mm and working width 3600 mm (with 600 mm shoes).

Optional Extreme Service Undercarriage. The 345C UHD can be mounted on a 365C L Undercarriage (variable gauge) for increased durability in extreme conditions. Its 345C-type carbody assures the same transport width (less than 3 m).

Track Guiding Guards. Full length track guiding guards complete the machine's guarding package.



Operator Station

Designed for comfort, safety and ease of operation.

Hydraulically Tiltable Cab.

The hydraulically tiltable cab tilts back from 0 to 30 degrees to further improve upward visibility and to allow the operator to adopt a more comfortable body position.

The tiltable cab is integrated into the upper frame and therefore does not increase the machine's shipping height. Thanks to the integration into the upper frame, no tilt parts are exposed to the demolition environment. To reduce vibrations and noise, the cab shell is attached to the frame with viscous mounts.

Automatic Climate Control. Fully automatic climate control adjusts temperature and flow and determines which air outlet is best in each situation.

Ergonomic Control Placement. The operator work station is quiet with ergonomic control placement and convenient adjustments,

low lever and pedal effort, ergonomic seat design and highly efficient ventilation.

The result is a cab that puts the operator firmly and comfortably in control to enhance productivity.

Falling Object Guard. An ISO 3449-1984 certified falling object guard on top and front of the cab is standard. The crossbars of the top guard are angled in line with the operator's sight for enhanced visibility of the work tool. The front guard swings out for easy windshield cleaning.

High Visibility Cab. The laminated safety glass front window is one-piece with a bottom mounted parallel wiper for excellent visibility. For enhanced upward visibility, the increased impact resistant top window extends completely to the rear and has a wiper and washer. The upper left side door window can slide open.



Booms, Sticks and Work Tools

Maximum versatility gets the best out of your machine.

Boom Hook System. The front parts are equipped with a reliable and safe hook system between the boom foot and the boom nose. Compared to the traditional pin-mounted joint, the hook system significantly reduces the time needed to change between the Ultra-high front parts and the short retrofit configuration. In principle, the boom hook system consists of a hook system to pick up the front parts and a mechanical expander pin to secure these front parts onto the boom foot. The absence of any hydraulic part and the full length heavy duty one-piece securing pin ensure a safe and reliable operation. The operator has an excellent view of the hook system from the cab to easily change the front parts.

Retrofit Capability. A short boom nose can be hooked onto the boom foot. To maximize the machine's extreme versatility, this boom nose can be put in two positions. The straight position is ideal for working in above ground level applications, such as low level demolition or sorting, and the bent position can be used for applications such as digging or truck loading.

Dedicated Ultra-High Demolition Linkage. Because Ultra-high demolition applications require a different working envelope than standard applications, a purpose designed linkage is standard on the Ultra-high demolition front parts. Besides providing an optimized working envelope, this linkage also greatly improves tool controllability in every position.

Tool Cylinder Protection. To prevent damage to the tool cylinder rod caused by falling concrete and debris, the tool cylinder is equipped with a heavy duty metal cover. Thanks to its unique construction, the cover protects the cylinder rod in every position.

Lowering Control Devices. For increased safety and controllability lowering control devices are installed on all boom and stick cylinders, and tool cylinder.

Face-to-Face Ball Valves. All hydraulic lines between boom foot and boom nose are fitted with face-to-face ball valves. This system assures an unmatched reliability while avoiding oil spillage.

Work Tools Matching Guide**

When choosing between various work tool models that can be installed onto the same machine configuration, consider work tool application, productivity requirements, and durability. Refer to work tool specifications for application recommendations and productivity information.



Without quick coupler		345C L		345C L HVG		345C ES	
		26 m	28 m	26 m	28 m	26 m	28 m
Multi-Processors	MP15 CC, CR, PP, S						
	MP20 CC, CR, S, TS		×		×		×
	MP20 PP	×	×		×		×
Crushers	VHC-30						
	VHC-40		×		×		×
Hydraulic Shears	S320						
Demolition and Sorting Grapples	G315						
	G320		×				
	G320B-D						
With quick coupler							
Quick Coupler	CW-40						
	CW-45						
	CW-40S						
	CW-45S						
Multi-Processors	MP15 CC, CR, S						
	MP15 PP		×				
	MP20 CC, CR, S, TS		×		×		×
	MP20 PP	×	×		×		×
Crushers	VHC-30						
	VHC-40		×		×		×
Hydraulic Shears	S320						
Demolition and Sorting Grapples	G315						
	G320		×				
	G320B-D						

* With Hydraulic Variable Gauge Undercarriage.

** For machines equipped with Ultra-high Demolition front parts.

- 360° Working Range
- Over the front only
- Recommended
- Available
- × Not recommended

Service and Maintenance

Simplified service and maintenance save you time and money.



Extended Service Intervals.

Extended service and maintenance intervals increase machine availability. The maintenance intervals for engine oil, engine oil filter and water separator for fuel line have been extended to 500 hours, hydraulic oil to 2000 hours for normal applications with S•O•SSM analysis monitoring.

Capsule Filter. The hydraulic return filters are located in the hydraulic tank. The filter elements are removable without spilling hydraulic oil.

Pilot Hydraulic System Filter. Pilot hydraulic system filter keeps contaminants from the pilot system and is located in the pump compartment.



Radial Seal Main Air Cleaner.

Radial seal main air cleaner with pre-cleaner has a double-layered filter element for more efficient filtration. No tools are required to change the element.

Fuel-Water Separator. The water separator has a primary fuel filter element and is located in the air cleaner compartment for easy access from the ground.

Service Points. Service points are centrally located with easy access to facilitate routine maintenance.

Oil Sample and Pressure Ports. Oil sample and pressure ports provide easy checking of machine condition and are standard on every machine.

Greasing Points. A concentrated remote greasing block on the boom delivers grease to hard-to-reach locations.

Complete Customer Support

Cat dealer services help you operate longer with lower costs.



Machine Selection. Make detailed comparisons of the machines you are considering before you buy. What are the job requirements, machine attachments and operating hours? What production is needed? Your Cat dealer can provide recommendations.

Purchase. Consider the financing options available as well as day-to-day operating costs. This is also the time to look at dealer services that can be included in the cost of the machine to yield lower equipment owning and operating costs over the long run.

Customer Support Agreements. Cat dealers offer a variety of product support agreements, and work with customers to develop a plan the best meets specific needs. These plans can cover the entire machine, including attachments, to help protect the customer's investment.

Operation. Improving operating techniques can boost your profits. Your cat dealer has videotapes, literature and other ideas to help you increase productivity, and Caterpillar offers certified operator training classes to help maximize the return on your investment.

Product Support. You will find nearly all parts at our dealer parts counter. Cat dealers utilize a worldwide computer network to find in-stock parts to minimize machine downtime. You can save money with Cat remanufactured components.

Maintenance Services. Repair option programs guarantee the cost of repairs up front. Diagnostic programs such as Scheduled Oil Sampling, Coolant Sampling and Technical Analysis help you avoid unscheduled repairs.

Replacement. Repair, rebuild or replace? Your Cat dealer can help you evaluate the cost involved so you can make the right choice.

Dimensions and Weights

With ultra-high demolition front. All dimensions and weights are approximate.

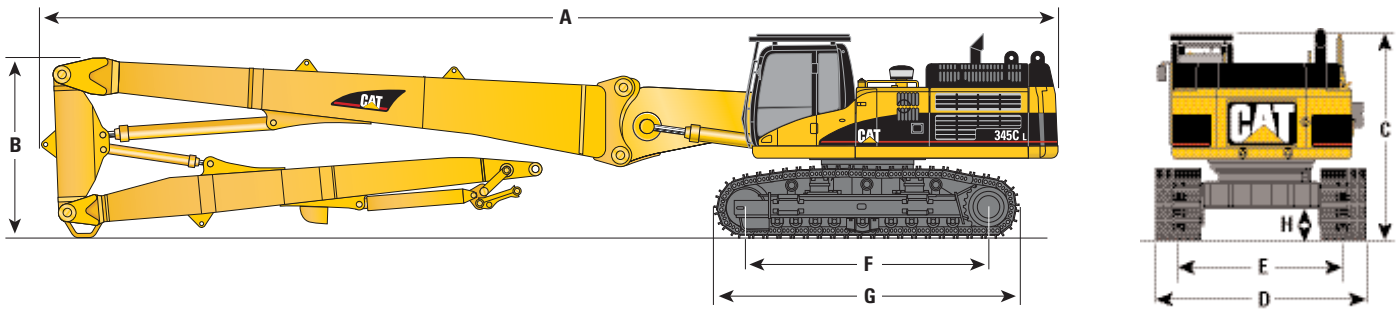

		L	HVG	ES
A Shipping length	mm	17 800	17 800	17 800
B Boom height	mm	3 110	3 110	3 200
C Cab height with Falling Object Guard (FOG)	mm	3 740	3 720	3 850
D Overall width with 600 mm shoes	mm	2 990	3 000	–
with 650 mm shoes	mm	–	–	2 990
Overall width with 600 mm shoes	mm	3 490	3 650	–
with 650 mm shoes	mm	–	–	3 400
E Track gauge Fully retracted	mm	2 390	2 400	2 340
Fully extended	mm	2 890	3 010	2 750
F Length to center of roller	mm	4 340	4 340	4 710
G Track length	mm	5 340	5 340	5 860
H Ground clearance	mm	740	460	830
Weight (UHD 26 m configuration)	kg	57 870	63 830	66 650
Weight (UHD 28 m configuration)	kg	58 240	64 200	67 020

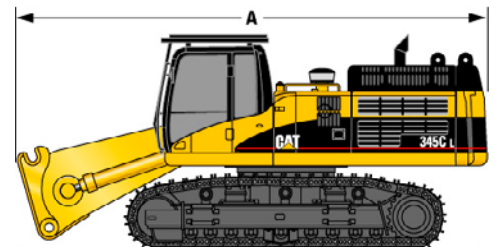

Base Machine

		L	HVG	ES
A Length	mm	7 810	7 810	7 810
Weight	kg	47 320	53 280	56 100

Engine

Cat C13 with ACERT Technology

Net Power at 1800 rpm

ISO 9249 239 kW/325 hp

EEC 80/1269 239 kW/325 hp

Bore 130 mm

Stroke 157 mm

Displacement 12.5 liters

- C13 meets Stage IIIA emission requirements.
- Net power advertised is the power available at the flywheel when the engine is equipped with fan, air cleaner, muffler, and alternator.

Sound

Operator Sound

- The operator sound level measured according to the procedures specified in ISO 6394:1998 is 75 dB(A), for cab offered by Caterpillar, when properly installed and maintained and tested with the doors and windows closed.

Exterior Sound

- The labeled spectator sound power level measured according to the test procedures and conditions specified in 2000/14/EC is 106 dB(A).

Hydraulic System

Main System

Maximum flow 2 x 360 l/min

Maximum pressure

Normal 350 bar

Heavy lift 360 bar

Travel 350 bar

Swing 314 bar

Pilot System

Maximum flow 43 l/min

Maximum pressure 41 bar

Cab/FOGS

Cab/FOGS meets ISO 10262.

Brakes

Meets the standard ISO 10265:1998

Swing Mechanism

Swing Speed 8.6 rpm

Swing Torque 149 kNm

Drive

With long variable gauge undercarriage.

Maximum Travel Speed 4.4 km/h

Maximum Drawbar Pull 338 kN

Service Refill Capacities

	Liters
Fuel Tank	705
Cooling System	61
Engine Oil	42
Swing Drive (each)	10
Final Drive (each)	15
Hydraulic system (including tank)	570
Hydraulic tank	243

Dimensions and Weights – Straight and Bent Position

All dimensions and weights are approximate.

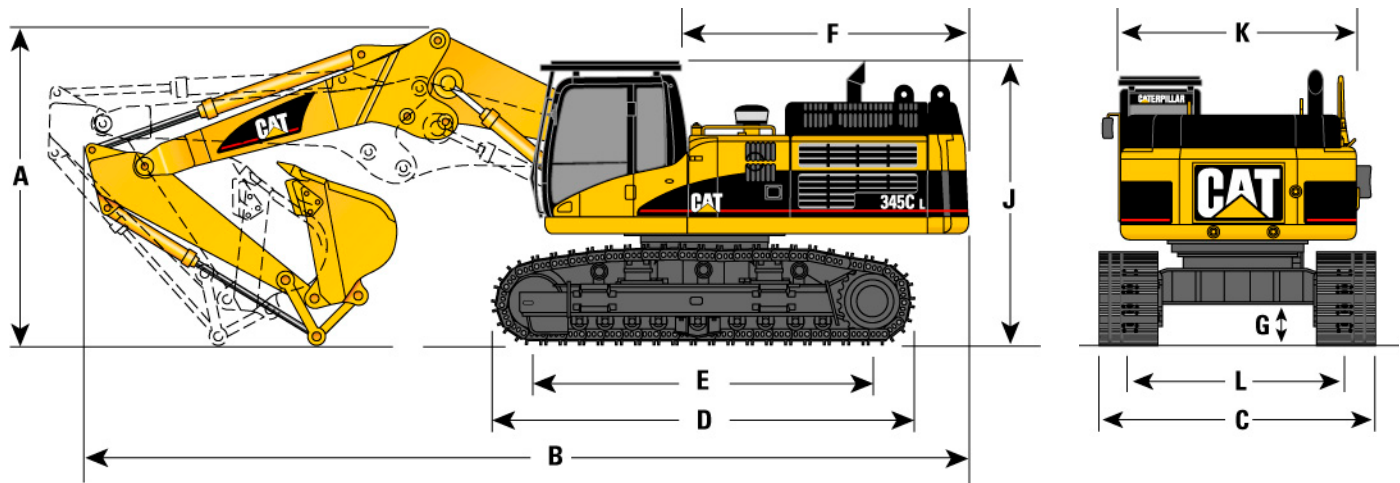

		L	HVG	ES
A Shipping height ***	Straight Position			
	2900 stick	mm	4000	4000
	3400 stick	mm	3910	3910
	Bent Position			
	2900 stick	mm	4225	4225
	3400 stick	mm	4100	4100
B Overall Length ***	Straight Position			
	2900 stick	mm	12 880	12 880
	3400 stick	mm	12 850	12 850
	Bent Position			
	2900 stick	mm	12 140	12 140
	3400 stick	mm	12 100	12 100

		L	HVG	ES
C Overall width **	with 600 mm shoes	mm	2990	3000
	with 650 mm shoes	mm	–	–
D Track length	mm	5340	5340	5860
E Length to center of rollers	mm	4340	4340	4710
F Tail swing radius	mm	3765	3765	3765
G Ground clearance	mm	740	460	830
J Cab height	with Overhead Guard	mm	3740	3720
		mm	3850	
K Body width	mm	2995	2995	2995
L Track gauge	Narrow Gauge	mm	2390	2400
	Working Gauge	mm	2890	3010
Weight*	2900 stick	kg	53 390	62 350
	3400 stick	kg	62 350	65 170
	3400 stick	kg	56 270	62 230

* With retrofit boom nose, stick, linkage, bucket, undercarriage, tiltable cab, FOG and full fuel tank.

** With tracks fully retracted.

*** With stick cylinder extended. Retracting the stick cylinder might decrease the shipping height but will increase shipping length.

Working Ranges

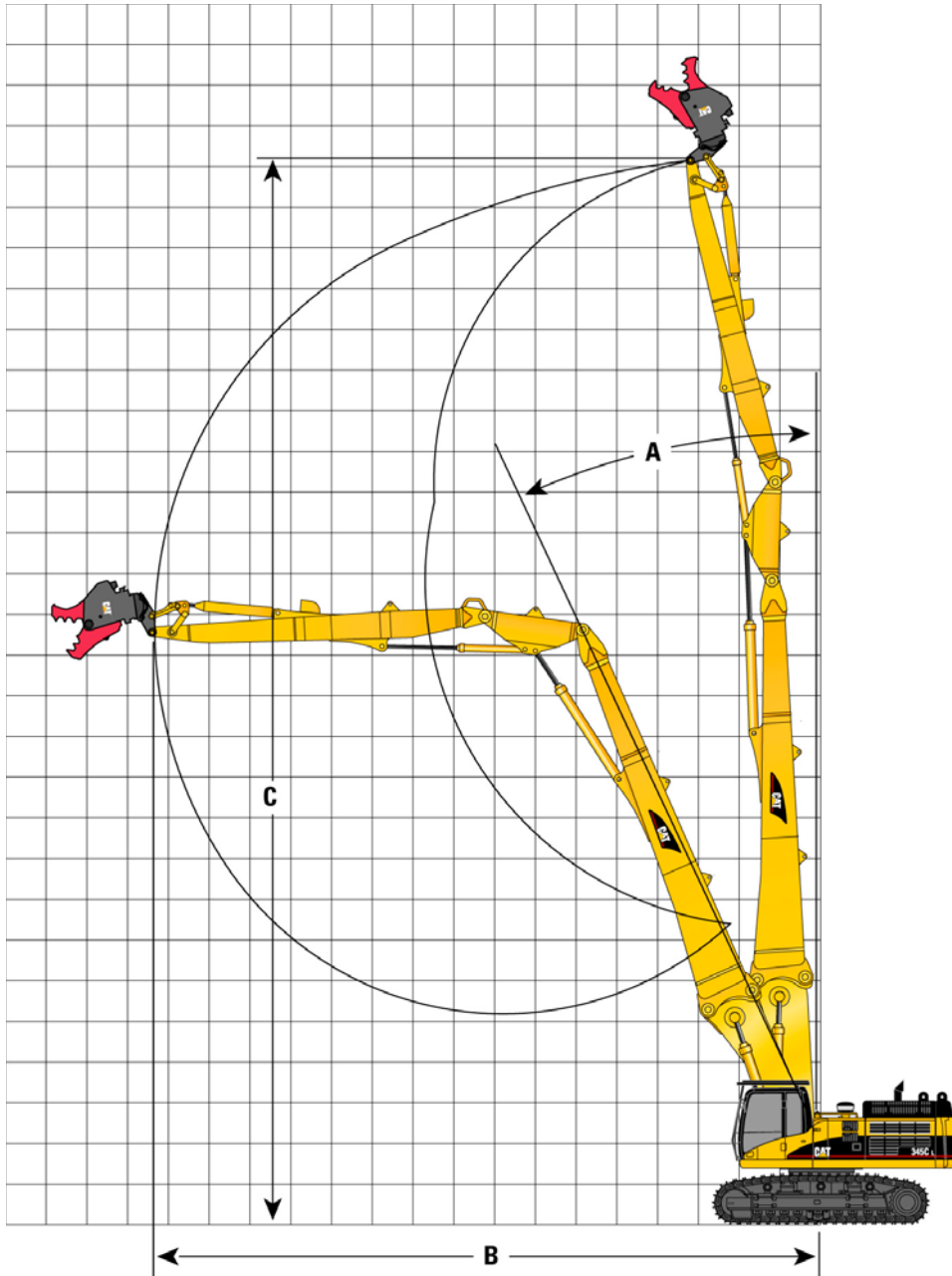

Maximum tool weight*

with L undercarriage (26/28 m)	
over front	3300/2500 kg
over side	2500/2000 kg
with hydraulic variable gauge undercarriage (26/28 m)	
over front	3300/2500 kg
over side	3000/2500 kg
with extreme service undercarriage (26/28 m)	
over front	3300/2500 kg
over side	3000/2500 kg

A Maximum allowable angle from vertical	25°
B Maximum horizontal reach (26 m)	16 450 mm
Maximum horizontal reach (28 m)	18 150 mm
C Maximum pin height (26 m)	26 150 mm
Maximum pin height (28 m)	27 850 mm

Range is applicable in 360° and dependent on undercarriage choice and maximum weight of work tool.

* Design of the mounting bracket is critical. Weight includes mounting bracket and Quick Coupler (if any). Distance between stick nose and work tool must be 1500 mm or less.

Working Ranges – Straight Position

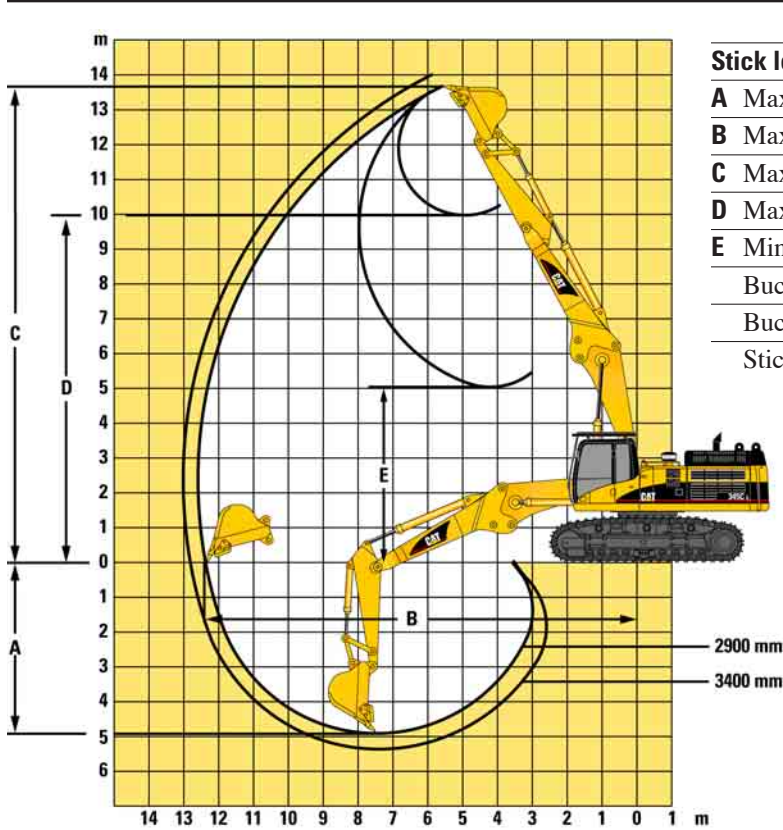

		R2.9T	R3.4T
Stick length	mm	2900	3400
A Maximum Digging Depth	mm	-4900	-5350
B Maximum Reach at Ground Level	mm	12 370	12 800
C Maximum Cutting Height	mm	13 710	14 040
D Maximum Loading Height	mm	9980	10 300
E Minimum Loading Height	mm	5060	4620
Bucket Tip Radius	mm	1890	1890
Bucket Force (SAE)	kN	229	229
Stick Force (SAE)	kN	212	194

Working Ranges – Bent Position

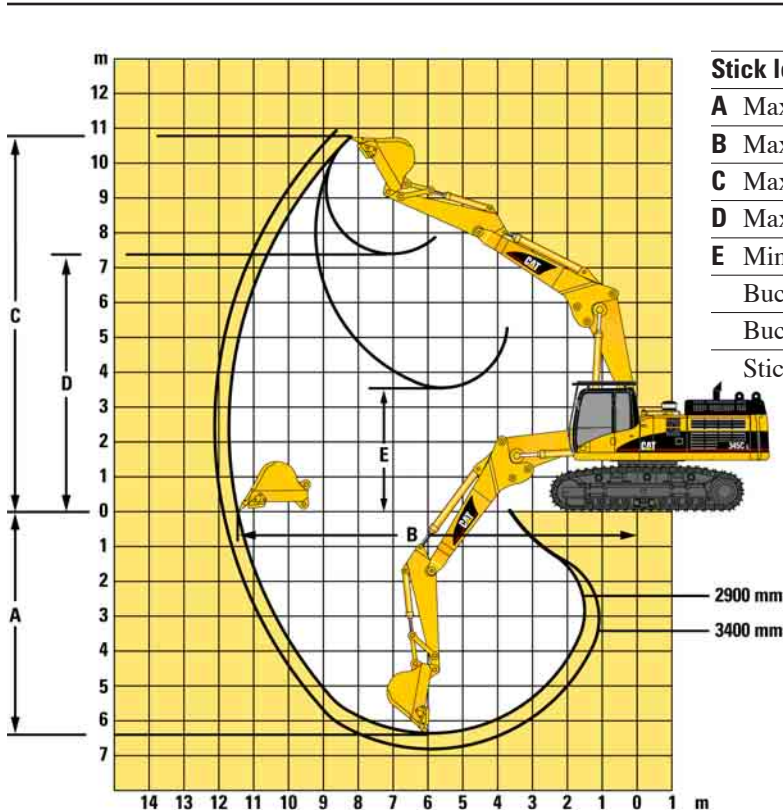

		R2.9T	R3.4T
Stick length	mm	2900	3400
A Maximum Digging Depth	mm	-6350	-6800
B Maximum Reach at Ground Level	mm	11 470	11 880
C Maximum Cutting Height	mm	10 770	10 920
D Maximum Loading Height	mm	7420	7570
E Minimum Loading Height	mm	3540	3100
Bucket Tip Radius	mm	1890	1890
Bucket Force (SAE)	kN	229	229
Stick Force (SAE)	kN	212	194

Lift capacities – Straight Position

All weights are in kg

345C L

Short Stick Demolition

2900 mm

Shoes

















600 mm

Bucket Capacity

2.2 m³

Bucket Weight

2300 kg

	4.50 m		6.00 m		7.50 m		9.00 m		10.50 m		12.00 m				m
															
12.00 m													*5220	*5220	7.21
10.50 m			*9500	*9500	*6730	*6730							*4440	*4440	9.18
9.00 m			*11 660	*11 660	*11 160	*11 160							*4080	*4080	10.45
7.50 m			*13 120	*13 120	*12 450	11 700	*10 560	8120					*3910	*3910	11.31
6.00 m	*22 090	*22 090	*16 310	*16 310	*12 980	11 190	*10 750	7920	*5820	5590			*3860	*3860	11.87
4.50 m			*17 470	15 080	*13 530	10 490	*10 970	7580	*9020	5510			*3920	*3920	12.18
3.00 m			*18 050	13 710	*13 840	9770	*11 050	7190	*8890	5340			*4070	3920	12.27
1.50 m			*17 550	12 810	*13 650	9200	*10 820	6850	*8490	5180			*4330	3960	12.13
0 m			*15 980	12 420	*12 790	8860	*10 100	6630	*7570	5090			*4720	4200	11.77
-1.50 m			*13 540	12 400	*11 150	8750	*8690	6560							
-3.00 m			*10 180	*10 180	*8550	*8550	*6180	*6180							

345C L

Medium Stick Demolition

3400 mm

Shoes

















600 mm

Bucket Capacity

2 m³

Bucket Weight

2190 kg

	4.50 m		6.00 m		7.50 m		9.00 m		10.50 m		12.00 m				m
															
12.00 m			*7770	*7770									*4360	*4360	8.01
10.50 m					*8210	*8210							*3740	*3740	9.78
9.00 m					*9780	*9780	*7380	*7380					*3440	*3440	10.97
7.50 m			*10 700	*10 700	*10 890	*10 890	*9810	8390					*3290	*3290	11.78
6.00 m	*17 530	*17 530	*14 930	*14 930	*12 760	11 490	*10 640	8150	*7930	5850			*3250	*3250	12.32
4.50 m			*17 220	15 590	*13 410	10 780	*10 940	7780	*9100	5700			*3300	*3300	12.62
3.00 m			*18 080	14 190	*13 860	10 040	*11 110	7370	*9060	5500			*3440	*3440	12.7
1.50 m			*17 990	13 170	*13 860	9420	*11 010	7000	*8780	5300			*3660	*3660	12.57
0 m	*7780	*7780	*16 810	12 660	*13 230	9020	*10 460	6740	*8100	5160			*4010	*3970	12.22
-1.50 m	*13 100	*13 100	*14 670	12 530	*11 840	8850	*9300	6620	*6690	5140			*3950	*3950	11.63
-3.00 m			*11 600	*11 600	*9550	8890	*7210	6670							

345C L HVG

Short Stick Demolition

2900 mm

Shoes

















600 mm

Bucket Capacity

2.2 m³

Bucket Weight

2300 kg

	4.50 m		6.00 m		7.50 m		9.00 m		10.50 m		12.00 m				m
															
12.00 m													*5240	*5240	7.18
10.50 m			*9470	*9470									*4450	*4450	9.16
9.00 m			*11 650	*11 650	*11 120	*11 120							*4080	*4080	10.44
7.50 m			*13 090	*13 090	*12 450	*12 450	*10 560	9500					*3910	*3910	11.31
6.00 m	*22 050	*22 050	*16 300	*16 300	*12 970	12 970	*10 750	9310	*5730	*5730			*3860	*3860	11.87
4.50 m			*17 460	*17 460	*13 530	12 260	*10 970	8960	*9020	6650			*3910	*3910	12.18
3.00 m			*18 050	16 130	*13 840	11 530	*11 050	8570	*8900	6480			*4070	*4070	12.27
1.50 m			*17 560	15 210	*13 660	10 950	*10 820	8230	*8490	6310			*4320	*4320	12.13
0 m			*16 010	14 810	*12 810	10 600	*10 110	8000	*7580	3220			*4720	*4720	11.78
-1.50 m			*13 580	*13 580	*11 180	10 490	*8710	7930							
-3.00 m			*10 230	*10 230	*8590	*8590	*6220	*6220							



Load Point Height



Load Radius Over Front



Load Radius Over Side



Load at Maximum Reach

* Limited by hydraulic rather than tipping load.

The above loads are in compliance with hydraulic excavator lift capacity ratings standard ISO 10567, they do not exceed 87% of hydraulic lifting capacity or 75% of tipping capacity. Weight of all lifting accessories must be deducted from the above lifting capacities.

Lift capacities – Straight Position

All weights are in kg

345C L HVG

Medium Stick Demolition

3400 mm

Shoes

















600 mm

Bucket Capacity

2 m³

Bucket Weight

2190 kg

	4.50 m		6.00 m		7.50 m		9.00 m		10.50 m		12.00 m				m
															
12.00 m			*7670	*7670									*4370	*4370	7.98
10.50 m					*8170	*8170							*3750	*3750	9.76
9.00 m					*9770	*9770	*7330	*7330					*3440	*3440	10.96
7.50 m			*10680	*10680	*10870	*10870	*9790	9780					*3290	*3290	11.78
6.00 m	*17270	*17270	*14830	*14830	*12760	*12760	*10640	9540	*7890	6980			*3250	*3250	12.31
4.50 m			*17200	*17200	*13400	12560	*10930	9170	*9090	6840			*3300	*3300	12.61
3.00 m			*18080	16620	*13860	11810	*11110	8760	*9060	6630			*3430	*3430	12.7
1.50 m			*18000	15580	*13870	11180	*11010	8380	*8790	6430			*3660	*3660	12.57
0 m	*7730	*7730	*16830	15050	*13240	10770	*10470	8120	*8110	6290			*4010	*4010	12.22
-1.50 m	*13030	*13030	*14710	*14710	*11870	10590	*9310	8000	*6720	6260			*3970	*3970	11.64
-3.00 m			*11640	*11640	*9590	*9590	*7250	*7250							

345C ES

Short Stick Demolition

2900 mm

Shoes

















650 mm

Bucket Capacity

2.2 m³

Bucket Weight

2300 kg

	4.50 m		6.00 m		7.50 m		9.00 m		10.50 m		12.00 m				m
															
12.00 m													*5140	*5140	7.39
10.50 m			*9680	*9680	*7580	*7580							*4410	*4410	9.29
9.00 m			*11700	*11700	*11270	*11270							*4060	*4060	10.53
7.50 m			*13340	*13340	*12480	*12480	*10570	9190					*3900	*3900	11.36
6.00 m	*22290	*22290	*16400	*16400	*13020	12480	*10770	8980	*6280	*6280			*3860	*3860	11.9
4.50 m			*17540	16720	*13570	11770	*10990	8630	*9020	6410			*3920	*3920	12.2
3.00 m			*18060	15380	*13850	11060	*11050	8240	*8880	6240			*4080	*4080	12.27
1.50 m			*17470	14530	*13610	10510	*10780	7920	*8440	6080			*4350	*4350	12.11
0 m			*15840	14180	*12700	10190	*10200	7700	*7470	5990			*4760	*4760	11.73
-1.50 m			*13330	*13330	*11000	10090	*8550	7650							
-3.00 m					*8310	*8310	*5930	*5930							

345C ES

Medium Stick Demolition

3400 mm

Shoes

















650 mm

Bucket Capacity

2 m³

Bucket Weight

2190 kg

	4.50 m		6.00 m		7.50 m		9.00 m		10.50 m		12.00 m				m
															
12.00 m			*8280	*8280									*4300	*4300	8.17
10.50 m					*8440	*8440							*3710	*3710	9.88
9.00 m					*9850	*9850	*7650	*7650					*3420	*3420	11.04
7.50 m			*10850	*10850	*11010	*11010	*9940	9460					*3280	*3280	11.83
6.00 m	*19350	*19350	*15550	*15550	*12810	12770	*10670	9210	*8130	6750			*3250	*3250	12.35
4.50 m			*17300	17220	*13450	12060	*10950	8840	*9100	6600			*3310	*3310	12.63
3.00 m			*18120	15850	*13880	11330	*11120	8430	*9050	6390			*3450	*3450	12.69
1.50 m			*17940	14880	*13840	10730	*10990	8070	*8750	6200			*3680	*3680	12.55
0 m	*8120	*8120	*16680	14400	*13160	10350	*10400	7820	*8030	6070			*4040	*4040	12.18
-1.50 m	*13540	*13540	*14490	14290	*11710	10190	*9180	7710	*6550	6050					
-3.00 m			*11340	*11340	*9350	*9350	*7010	*7010							



Load Point Height



Load Radius Over Front



Load Radius Over Side



Load at Maximum Reach

* Limited by hydraulic rather than tipping load.

The above loads are in compliance with hydraulic excavator lift capacity ratings standard ISO 10567, they do not exceed 87% of hydraulic lifting capacity or 75% of tipping capacity. Weight of all lifting accessories must be deducted from the above lifting capacities.

Lift capacities – Bent Position

All weights are in kg

345C L

Short Stick Demolition

2900 mm

Shoes

















600 mm

Bucket Capacity

2.2 m³

Bucket Weight

2300 kg

	3.00 m		4.50 m		6.00 m		7.50 m		9.00 m		10.50 m				m
															
9.00 m							*7120	*7120					*3990	*3990	9.37
7.50 m							*10 440	*10 440					*3880	*3880	10.34
6.00 m							*11 080	*11 080	*9520	8330			*3910	*3910	10.96
4.50 m			*20 670	*20 670	*14 980	*14 980	*12 000	*11 280	*10 180	8050			*4060	*4060	11.29
3.00 m			*19 070	*19 070	*16 720	15 040	*12 950	*10 560	*10 660	7680			*4340	*4340	11.38
1.50 m			*13 640	*13 640	*17 840	13 930	*13 650	9920	*11 010	7320			*4770	*4770	11.23
0 m			*17 160	*17 160	*18 050	13 270	*13 870	9460	*11 030	7040			*5410	5100	10.84
-1.50 m	*13 320	*13 320	*17 530	*17 530	*17 320	13 020	*13 430	9230	*10 460	6920			*6390	5730	10.16
-3.00 m			*18 270	*18 270	*15 560	13 090	*12 040	9250							
-4.50 m			*15 450	*15 450	*12 280	*12 280	*8780	*8780							

345C L

Medium Stick Demolition

3400 mm

Shoes

















600 mm

Bucket Capacity

2 m³

Bucket Weight

2190 kg

	3.00 m		4.50 m		6.00 m		7.50 m		9.00 m		10.50 m				m
															
9.00 m													*3360	*3360	9.88
7.50 m									*6230	*6230			*3260	*3260	10.79
6.00 m							*10 670	*10 670	*9450	8600			*3290	*3290	11.38
4.50 m			*19 530	*19 530	*14 420	*14 420	*11 660	11 580	*9950	8280			*3430	*3430	11.7
3.00 m			*22 640	*22 640	*16 320	15 510	*12 710	10 840	*10 520	7890	*6300	5790	*3680	*3680	11.79
1.50 m			*16 910	*16 910	*17 700	14 320	*13 550	10 160	*10 970	7490	*6890	5600	*4050	*4050	11.64
0 m			*17 800	*17 800	*18 210	13 550	*13 950	9650	*11 140	7170			*4610	*4610	11.26
-1.50 m	*12 660	*12 660	*17 970	*17 970	*17 790	13 190	*13 730	9350	*10 810	6990			*5460	5360	10.62
-3.00 m	*17 440	*17 440	*18 690	*18 690	*16 370	13 150	*12 670	9290	*9550	6990			*5930	*5930	9.65
-4.50 m			*17 410	*17 410	*13 610	13 410	*10 200	9490							

m

345C L HVG

Short Stick Demolition

2900 mm

Shoes

















600 mm

Bucket Capacity

2.2 m³

Bucket Weight

2300 kg

	3.00 m		4.50 m		6.00 m		7.50 m		9.00 m		10.50 m				m
															
9.00 m							*7030	*7030					*3990	*3990	9.36
7.50 m							*10 430	*10 430					*3880	*3880	10.33
6.00 m							*11 070	*11 070	*9480	*9480			*3910	*3910	10.95
4.50 m			*20 620	*20 620	*14 950	*14 950	*11 990	*11 990	*10 170	9440			*4060	*4060	11.29
3.00 m			*19 130	*19 130	*16 700	*16 700	*12 940	12 330	*10 660	9070			*4340	*4340	11.38
1.50 m			*13 630	*13 630	*17 830	16 350	*13 640	11 680	*11 010	8700			*4770	*4770	11.24
0 m			*17 090	*17 090	*18 050	15 680	*13 870	11 220	*11 030	8420			*5410	*5410	10.84
-1.50 m	*13 230	*13 230	*17 530	*17 530	*17 330	15 420	*13 440	10 980	*10 470	8290			*6370	*6370	10.17
-3.00 m			*18 250	*18 250	*15 590	15 480	*12 070	10 990							
-4.50 m			*15 520	*15 520	*12 340	*12 340	*8840	*8840							



Load Point Height



Load Radius Over Front



Load Radius Over Side



Load at Maximum Reach

* Limited by hydraulic rather than tipping load.

The above loads are in compliance with hydraulic excavator lift capacity ratings standard ISO 10567, they do not exceed 87% of hydraulic lifting capacity or 75% of tipping capacity. Weight of all lifting accessories must be deducted from the above lifting capacities.

Lift capacities – Bent Position

All weights are in kg

345C L HVG

Medium Stick Demolition

3400 mm

Shoes

















600 mm

Bucket Capacity

2 m³

Bucket Weight

2190 kg

	3.00 m		4.50 m		6.00 m		7.50 m		9.00 m		10.50 m				m	
																
9.00 m														*3360	*3360	9.86
7.50 m									*6180	*6180				*3260	*3260	10.78
6.00 m							*10660	*10660	*9420	*9420				*3290	*3290	11.37
4.50 m			*19470	*19470	*14390	*14390	*11650	*11650	*9950	9670				*3430	*3430	11.7
3.00 m			*22760	*22760	*16300	*16300	*12700	12620	*10510	9270	*6280	*6280	*3670	*3670	11.79	
1.50 m			*16940	*16940	*17690	16750	*13540	11920	*10970	8870	*6890	6730	*4050	*4050	11.65	
0 m			*17800	*17800	*18210	15960	*13950	11400	*11140	8550			*4600	*4600	11.27	
-1.50 m	*12580	*12580	*17960	*17960	*17800	15590	*13740	11100	*10820	8370			*5440	*5440	10.63	
-3.00 m	*17440	*17440	*18670	*18670	*16390	15550	*12690	11030	*9580	8370			*5960	*5960	9.67	
-4.50 m			*17470	*17470	*13660	*13660	*10250	*10250								

345C ES

Short Stick Demolition

2900 mm

Shoes

















650 mm

Bucket Capacity

2.2 m³

Bucket Weight

2300 kg

	3.00 m		4.50 m		6.00 m		7.50 m		9.00 m		10.50 m				m	
																
9.00 m							*7600	*7600						*3970	*3970	9.45
7.50 m							*10470	10470						*3870	*3870	10.39
6.00 m							*11140	*11140	*9780	9390				*3920	*3920	10.99
4.50 m			*20960	*20960	*15110	*15110	*12070	*12070	*10210	9110				*4080	*4080	11.31
3.00 m			*18090	*18090	*16830	16690	*13010	11850	*10700	8740				*4370	*4370	11.38
1.50 m			*13730	*13730	*17890	15620	*13680	11220	*11030	8380				*4810	*4810	11.21
0 m			*17370	*17370	*18030	15000	*13860	10780	*11010	8110				*5470	*5470	10.8
-1.50 m	*13860	*13860	*17560	*17560	*17230	14780	*13360	10570	*10380	8000				*6480	*6480	10.1
-3.00 m			*18360	*18360	*15380	14860	*11890	10600								
-4.50 m					*11960	*11960										

345C ES

Medium Stick Demolition

3400 mm

Shoes

















650 mm

Bucket Capacity

2 m³

Bucket Weight

2190 kg

	3.00 m		4.50 m		6.00 m		7.50 m		9.00 m		10.50 m				m	
																
9.00 m														*3350	*3350	9.96
7.50 m									*6540	*6540				*3260	*3260	10.84
6.00 m							*10740	*10740	*9480	*9480				*3300	*3300	11.41
4.50 m			*19820	*19820	*14560	*14560	*11740	*11740	*9990	9340				*3440	*3440	11.71
3.00 m			*22000	*22000	*16440	*16440	*12780	12120	*10560	8940	*6400	*6400	*3700	*3700	11.78	
1.50 m			*16760	*16760	*17770	16000	*13600	11450	*11000	8550	*6850	6490	*4090	*4090	11.62	
0 m	*7020	*7020	*17800	*17800	*18210	15270	*13960	10960	*11140	8240			*4660	*4660	11.23	
-1.50 m	*13090	*13090	*18000	*18000	*17720	14940	*13690	10680	*10760	8070			*5530	*5530	10.56	
-3.00 m	*17420	*17420	*18770	*18770	*16220	14920	*12550	10630	*9400	8090			*5760	*5760	9.57	
-4.50 m			*17050	*17050	*13340	*13340	*9930	*9930								



Load Point Height



Load Radius Over Front



Load Radius Over Side



Load at Maximum Reach

* Limited by hydraulic rather than tipping load.

The above loads are in compliance with hydraulic excavator lift capacity ratings standard ISO 10567, they do not exceed 87% of hydraulic lifting capacity or 75% of tipping capacity. Weight of all lifting accessories must be deducted from the above lifting capacities.

Standard Equipment

Standard equipment may vary. Consult your Caterpillar dealer for specifics.

Electrical

Alternator – 75 amp
Lights working
 Boom, both side
 Cab interior
 Cab mounted, two
 Frame mounted
Signal/warning horn

Engine/Powertrain

Automatic engine speed control
Automatic swing parking brake
Automatic travel parking brakes
Caterpillar C13 with ACERT technology
 Altitude capability to 2300 m without derating
Fine swing control
Fuel Filter
High ambient cooling, 48°C capability
Secondary engine shut-off switch
Side-by-side cooling system with separately mounted AC condenser and variable speed fan
Two speed travel
Water separator, with level indicator, for fuel line

Guards

Full length track guiding guards
Heavy duty bottom guards on upper frame
Heavy duty swivel guard on undercarriage
Heavy duty travel motor guards on undercarriage

Front Linkage

Boom foot with hook system
Face-to-face ball valve system

Operator Station

Adjustable armrest
Air conditioner, heater and defroster with automatic climate control
Ashtray and 24 volt lighter
Beverage/cup holder
Coat hook
Console mounted electronic type joysticks with adjustable gain and response
Electrical provision for seat heater
EU sound criteria package
Floor mat, washable
FOGS
Instrument panel and gauges with full color graphical display, start-up level checks
High resistant front windshield
Large skylight with wiper and washer
Literature compartment
Mirrors – left and right
Neutral lever (lock out) for all controls
Positive filtered ventilation, pressurized cab
Rear window, emergency exit
Retractable seat belt 51 mm width
Sliding upper door window
Storage compartment suitable for a lunch box
Sunshade for windshield and skylight
Tilting device (cab)
Travel control pedals with removable hand levers
Warming device
Windshield wipers and washers (upper and lower)

Track

Triple grouser shoes – 600 mm width, heavy duty
Grease lubricated track
Hydraulic track adjusters

Undercarriage

Long, variable gauge
Steps – four

Other Standard Equipment

Auxiliary hydraulic valve for hydro-mechanical tools
Boom lowering control device with SmartBoom
Cat batteries
Cat branded XT hoses and reusable couplings
Cat Datalink and capability to use ET
Caterpillar one key security system with locks for doors, cab and fuel cap
Combined control
Cross-roller type swing bearing
Counterweight 12 000 kg with lifting hook
Drive for auxiliary pump
Hand control pattern changer
Heavy lift mode
Medium pressure control
Radio, 24V
Regeneration circuit for boom and stick
S•O•SSM quick sampling valves for engine oil and hydraulic oil
Steel firewall between engine and hydraulic pumps
Thumb wheel joysticks
Wiring provisions for Product Link, Auto-lube System and lighted beacon

Optional Equipment

Optional equipment may vary. Consult your Caterpillar dealer for specifics.

Front Linkage

Bucket linkages
 TB-family for TB sticks
Sticks
 – R2.9TB
 – R3.4TB
Retrofit boom
UHD front boom

Undercarriage

Hydraulic Variable Gauge
Extreme Service

Auxiliary Controls and Lines

Auxiliary stick lines

Miscellaneous Options

Bio hydraulic oil package
Converter, 7 amp-12V
Electric refueling pump with auto shut-off
Fine filtration filter
Jump start terminals
Radiator screen
Reversible cooling fan including protective screen
Starting aid for cold weather with ether
Travel alarm with cut off switch

Operator Compartment

Lunch box storage with lid
Machine security system with programmable keys
Seat
 Adjustable high-back seat with mechanical suspension
 Adjustable high-back seat with air suspension
 Adjustable high-back heated seat with air suspension
Straight travel pedal

345C L Ultra-high Demolition

HEHH3546 (11/2006) hr

Materials and specifications are subject to change without notice.
Featured machines in photos may include additional equipment.
See your Caterpillar dealer for available options.

www.CAT.com
© 2006 Caterpillar
All rights reserved

CATERPILLAR[®]