

		EP13PNT - EP20PNT				EP13PNT	EP15PNT	EP16CPNT	EP18CPNT	EP16PNT	EP18PNT	EP20PNT
Mast Type	h3	h1	h4	h2/h5	Q @ c = 500mm	Q @ c = 500mm	Q @ c = 500mm	Q @ c = 500mm	Q @ c = 500mm	Q @ c = 500mm	Q @ c = 500mm	
	mm	mm	mm	mm	kg	kg	kg	kg	kg	kg	kg	
Simplex	2000	1480*	3045	80	1300	1500	1600	1800	1600	1800	2000	
	2560	1760*	3605	80	1300	1500	1600	1800	1600	1800	2000	
	2760	1860*	3805	80	1300	1500	1600	1800	1600	1800	2000	
	3000	1980*	4045	80	1300	1500	1600	1800	1600	1800	2000	
	3290	2125	4335	80	1300	1500	1600	1800	1600	1800	2000	
	3530	2245	4575	80	1300	1500	1600	1800	1600	1800	2000	
	3720	2385	4765	80	1300	1500	1600	1800	1600	1800	2000	
	4090	2570	5135	80	1300	1500	1600	1750	1600	1800	2000	
	4480	2775	5525	80	1275	1475	1600	1700	1600	1800	2000	
	5000	3035	6045	80	1200	1400	1525	1625	1600	1750	1925	
	5500	3285	6545	80	1125	1325	1425	1550	1500	1675	1850	
6000	3535	7045	80	1050	1250	1300	1425	1400	1550	1650		
Duplex	2800	1880*	3845	835	1300	1500	1600	1800	1600	1800	2000	
	3000	1980*	4045	935	1300	1500	1600	1800	1600	1800	2000	
	3295	2125	4340	1080	1300	1500	1600	1800	1600	1800	2000	
	3515	2245	4560	1200	1300	1500	1600	1800	1600	1800	2000	
	3700	2385	4745	1340	1300	1500	1600	1800	1600	1800	2000	
	4030	2570	5075	1525	1300	1500	1600	1750	1600	1800	2000	
	4310	2775	5465	1710	1300	1500	1600	1700	1600	1800	2000	
Triplex	3710	1780*	4755	735	1300	1500	1600	1800	1600	1800	2000	
	4010	1880*	5055	835	1300	1500	1600	1750	1600	1800	2000	
	4310	1980*	5355	935	1275	1475	1600	1725	1600	1800	2000	
	4750	2125	5795	1080	1225	1425	1550	1650	1600	1800	2000	
	5090	2245	6135	1200	1175	1375	1500	1600	1600	1775	1900	
	5490	2385	6535	1340	1125	1325	1450	1550	1550	1675	1825	
	5990	2570	7035	1525	1075	1275	1375	1450	1500	1650	1750	
	6490	2830	7535	1785	950	1050	1050	1050	1175	1175	1350	
	7000	3035	8045	1990	725	725	725	725	850	850	1100	

		EP16CPN - EP20PN				EP16CPN	EP18CPN	EP16PN	EP18PN	EP20PN
Mast Type	h3	h1	h4	h2/h5	Q @ c = 500mm	Q @ c = 500mm	Q @ c = 500mm	Q @ c = 500mm	Q @ c = 500mm	
	mm	mm	mm	mm	kg	kg	kg	kg	kg	
Simplex	2000	1480*	3045	80	1600	1800	1600	1800	2000	
	2560	1760*	3605	80	1600	1800	1600	1800	2000	
	2760	1860*	3805	80	1600	1800	1600	1800	2000	
	3000	1980*	4045	80	1600	1800	1600	1800	2000	
	3290	2125	4335	80	1600	1800	1600	1800	2000	
	3530	2245	4575	80	1600	1800	1600	1800	2000	
	3720	2385	4765	80	1600	1800	1600	1800	2000	
	4090	2570	5135	80	1600	1800	1600	1800	2000	
	4480	2775	5525	80	1600	1775	1600	1800	2000	
	5000	3035	6045	80	1600	1700	1600	1775	1925	
	5500	3285	6545	80	1550	1625	1600	1725	1850	
6000	3535	7045	80	1200	1200	1325	1325	1750		
Duplex	2800	1880*	3845	835	1600	1800	1600	1800	2000	
	3000	1980*	4045	935	1600	1800	1600	1800	2000	
	3295	2125	4340	1080	1600	1800	1600	1800	2000	
	3515	2245	4560	1200	1600	1800	1600	1800	2000	
	3700	2385	4745	1340	1600	1800	1600	1800	2000	
	4030	2570	5075	1525	1600	1800	1600	1800	2000	
	4310	2775	5465	1710	1600	1800	1600	1800	2000	
Triplex	3710	1780*	4755	735	1600	1800	1600	1800	2000	
	4010	1880*	5055	835	1600	1800	1600	1800	2000	
	4310	1980*	5355	935	1600	1775	1600	1800	2000	
	4750	2125	5795	1080	1600	1725	1600	1800	1950	
	5090	2245	6135	1200	1600	1675	1600	1750	1900	
	5490	2385	6535	1340	1550	1625	1600	1700	1850	
	5990	2570	7035	1525	1275	1275	1400	1400	1775	
	6490	2830	7535	1785	900	900	1025	1025	1325	
	7000	3035	8045	1990	625	625	750	750	1000	

Mast Performance and Capacity

- h1 Height with mast lowered
- h2 Standard free lift
- h3 Lift height
- h4 Height with mast raised
- h5 Full free lift
- Q Lifting capacity, rated load
- c Load centre (distance)

(Consult your dealer for the maximum back-tilt allowed to obtain the capacity specified)

* Lower than overhead guard.

Cat® Lift Trucks. Your partner in materials handling.

Since the 1960's we have been producing lift trucks designed to last and built to perform in some of the toughest environments in the world. Today those brand values of ruggedness, durability and serviceability are at the core of our complete range of lift truck and warehouse equipment.

Together with our dealer network we are dedicated to providing customers with comprehensive materials handling solutions and cost-effective machine selection.

Our 'off the shelf' parts availability in excess of 95% is the highest in the industry and is supported by online access to our other centralized departments in the USA, Singapore and Japan to provide a truly global service. We offer a variety of warranties and maintenance contracts tailored to your specific needs. Cat-trained service technicians respond quickly and efficiently when required, to keep your materials handling operation running smoothly and profitably.

To help spread the cost of ownership we also provide a full range of finance and rental options. For customers with continental operations our 'International Fleet Sales & Services' department delivers the benefits of the global Cat Lift Trucks network, through a single point of contact. For cost-effective solutions, or to find your nearest dealer, contact Cat Lift Trucks, your partner in materials handling.

info@catlifttruck.com
www.catlifttruck.com
www.catliftpower.com

CESC1396(09/11)
 ©2011, MCFE. All rights reserved.
 CAT, CATERPILLAR their respective logos, 'Caterpillar Yellow' and the 'Power Edge' trade dress, as well as corporate and product identity used herein, are trademarks of Caterpillar and may not be used without permission.
 Printed in The Netherlands.



**EP13PNT - EP15PNT - EP16CPNT - EP16PNT
 EP18CPNT - EP18PNT - EP20PNT - EP16CPN
 EP16PN - EP18CPN - EP18PN - EP20PN**
 Specifications

Electric powered lift trucks
 3 and 4 wheel, 48V, 1.3 - 2.0 tonnes

NOTE: Performance specifications may vary depending on standard manufacturing tolerances, vehicle condition, types of tyres, floor or surface conditions, applications, or operating environment. Trucks may be shown with non-standard options. Specific performance requirements and locally available configurations should be discussed with your Cat lift trucks Dealer. Cat Lift Trucks follows a policy of continual product improvement. For this reason, some materials, options and specifications could change without notice.



Characteristics		Cat Lift Trucks EP13PNT	Cat Lift Trucks EP15PNT	Cat Lift Trucks EP16CPNT	Cat Lift Trucks EP18CPNT	Cat Lift Trucks EP16PNT	Cat Lift Trucks EP18PNT	Cat Lift Trucks EP20PNT	Cat Lift Trucks EP16CPN	Cat Lift Trucks EP18CPN	Cat Lift Trucks EP16PN	Cat Lift Trucks EP18PN	Cat Lift Trucks EP20PN
1.01	Manufacturer (abbreviation)												
1.02	Manufacturer's model designation												
1.03	Power source: (battery, diesel, LP gas, petrol)	Electric	Electric	Electric	Electric	Electric	Electric	Electric	Electric	Electric	Electric	Electric	Electric
1.04	Operator type: pedestrian, (operator)-standing, -seated	Seated	Seated	Seated	Seated	Seated	Seated	Seated	Seated	Seated	Seated	Seated	Seated
1.05	Load capacity	Q (kg)	1300	1500	1600	1800	1600	1800	2000	1600	1800	1800	2000
1.06	Load centre distance	c (mm)	500	500	500	500	500	500	500	500	500	500	500
1.08	Load distance, axle to fork face	x (mm)	373	373	373	373	373	384	373	373	373	373	384
1.09	Wheelbase	y (mm)	1285	1285	1395	1395	1505	1505	1446	1446	1556	1556	1556
Weight													
2.01	Truck weight, without load / including battery (simplex mast, lowest lift height)	kg	2785	2980	3040	3140	3140	3235	3465	3050	3105	3105	3335
2.02	Axle loading with maximum load, front/rear (simplex mast, lowest lift height)	kg	3585/500	3915/565	4070/570	4395/545	4085/655	4400/635	4775/690	4015/635	4330/575	4055/650	4360/610
2.03	Axle loading without load, front/rear (simplex mast, lowest lift height)	kg	1400/1385	1395/1585	1470/1570	1470/1670	1555/1585	1555/1680	1600/1865	1450/1600	1445/1660	1560/1545	1550/1620
Wheels, Drive Train													
3.01	Tyres: V=solid, L=pneumatic, SE=solid pneumatic - front/rear		SE/SE	SE/SE	SE/SE	SE/SE	SE/SE	SE/SE	SE/SE	SE/SE	SE/SE	SE/SE	SE/SE
3.02	Tyre dimensions, front		18x7-8	18x7-8	18x7-8	18x7-8	18x7-8	18x7-8	200/50-10	18x7-8	18x7-8	18x7-8	200/50-10
3.03	Tyre dimensions, rear		140/55-9	140/55-9	140/55-9	140/55-9	140/55-9	140/55-9	16x6-8	16x6-8	16x6-8	16x6-8	16x6-8
3.05	Number of wheels, front/rear (x=driven)		2x/2	2x/2	2x/2	2x/2	2x/2	2x/2	2x/2	2x/2	2x/2	2x/2	2x/2
3.06	Track width (centre of tyres), front	b10 (mm)	920	920	920	920	920	938	920	920	920	920	938
3.07	Track width (centre of tyres), rear	b11 (mm)	174	174	174	174	174	174	898	898	898	898	898
Dimensions													
4.01	Mast tilt, forwards/backwards	α/β °	5/7.5	5/7.5	5/7.5	5/7.5	5/7.5	5/7.5	5/7.5	5/7.5	5/7.5	5/7.5	5/7.5
4.02	Height with mast lowered (see tables)	h1 (mm)	2125	2125	2125	2125	2125	2125	2125	2125	2125	2125	2125
4.03	Free lift (see tables)	h2 (mm)	80	80	80	80	80	80	80	80	80	80	80
4.04	Lift height (see tables)	h3 (mm)	3290	3290	3290	3290	3290	3290	3290	3290	3290	3290	3290
4.05	Overall height with mast raised	h4 (mm)	4335	4335	4335	4335	4335	4335	4335	4335	4335	4335	4335
4.07	Height to top of overhead guard	h6 (mm)	2050	2050	2050	2050	2050	2050	2050	2050	2050	2050	2050
4.08	Seat height	h7 (mm)	974	974	974	974	974	974	974	974	974	974	974
4.12	Tow coupling height	h10 (mm)	575	575	575	575	575	575	575	575	575	575	575
4.19	Overall length	l1 (mm)	2998	2998	3108	3108	3218	3218	3229	3302	3302	3412	3423
4.20	Length to fork face (includes fork thickness)	l2 (mm)	1848	1848	1958	1958	2068	2068	2079	2152	2152	2262	2273
4.21	Overall width	b1/b2 (mm)	1090	1090	1090	1090	1090	1140	1090	1090	1090	1090	1140
4.22	Fork dimensions (thickness, width, length)	s, e, l (mm)	35x100x1150	35x100x1150	35x100x1150	35x100x1150	35x100x1150	35x100x1150	35x100x1150	35x100x1150	35x100x1150	35x100x1150	35x100x1150
4.23	Fork carriage to DIN 15 173 A/B/no		2A	2A	2A	2A	2A	2A	2A	2A	2A	2A	2A
4.24	Fork carriage width	b3 (mm)	920	920	920	920	920	920	920	920	920	920	920
4.31	Ground clearance under mast, with load	m1 (mm)	95	95	95	95	95	95	95	95	95	95	95
4.32	Ground clearance at centre of wheelbase, with load (forks lowered)	m2 (mm)	85	85	85	85	85	85	85	85	85	85	85
4.33	Working aisle width with 1000 x1200 mm pallets, crosswise	Ast (mm)	3173	3173	3283	3283	3393	3393	3403	3473	3473	3588	3599
4.34	Working aisle width with 800 x1200 mm pallets, crosswise	Ast (mm)	2993	2993	3103	3103	3213	3213	3222	3273	3273	3388	3399
4.35	Turning circle radius	Wa (mm)	1475	1695	1585	1585	1695	1695	1900	1900	2015	2015	2015
4.36	Minimum distance between centres of rotation	b13 (mm)	0	0	0	0	0	0	481	481	544	544	544
Performance													
5.01	Travel speed, with/without load	km/h	16/16	16/16	16/16	16/16	16/16	16/16	17/17	17/17	17/17	17/17	17/17
5.02	Lifting speed, with/without load	m/s	0.5/0.6	0.5/0.6	0.5/0.6	0.44/0.6	0.5/0.6	0.44/0.6	0.4/0.6	0.5/0.6	0.44/0.6	0.44/0.6	0.4/0.6
5.03	Lowering speed, with/without load	m/s	0.52/0.5	0.52/0.5	0.52/0.5	0.52/0.5	0.52/0.5	0.52/0.5	0.52/0.5	0.52/0.5	0.52/0.5	0.52/0.5	0.52/0.5
5.05	Rated drawbar pull, with/without load	N	2810 / 3130	2720 / 3090	2680 / 3070	2610 / 3050	2650 / 3050	2580 / 3020	2480 / 2970	2680 / 3070	2610 / 3060	2660 / 3060	2600 / 3040
5.06	Maximum drawbar pull, with/without load (5 min short duty)	N	11390 / 11710	11290 / 11660	12020 / 12410	11950 / 12390	12160 / 12550	12090 / 12530	11980 / 12470	12020 / 12410	11950 / 12400	12170 / 12560	12110 / 12550
5.07	Gradeability, with/without load	%	11 / 18	10 / 16	11 / 16	9 / 15	9 / 15	9 / 15	8 / 14	10 / 16	9 / 16	9 / 16	9 / 15
5.08	Maximum gradeability, with/without load	%	28 / 35	26 / 35	27 / 35	25 / 35	26 / 35	25 / 35	23 / 35	27 / 35	25 / 35	27 / 35	25 / 35
5.09	Acceleration time (10 metres) with/without load	s	4.1 / 3.6	4.2 / 3.7	4.3 / 3.7	4.3 / 3.8	4.3 / 3.8	4.4 / 3.8	4.5 / 3.9	4.3 / 3.7	4.3 / 3.7	4.4 / 3.8	4.4 / 3.8
5.10	Service brakes (mechanical/hydraulic/electric/pneumatic)		Mech./hydr.	Mech./hydr.	Mech./hydr.	Mech./hydr.	Mech./hydr.	Mech./hydr.	Mech./hydr.	Mech./hydr.	Mech./hydr.	Mech./hydr.	Mech./hydr.
Electric motors													
6.01	Drive motor capacity (60 min. short duty)	kW	4.5x2	4.5x2	4.5x2	4.5x2	4.5x2	4.5x2	4.5x2	4.5x2	4.5x2	4.5x2	4.5x2
6.02	Lift motor output at 15% duty factor	kW	11.5	11.5	11.5	11.5	11.5	11.5	11.5	11.5	11.5	11.5	11.5
6.03	Battery to DIN 43531/35/36 A/B/C/no		DIN 43531 A	DIN 43531 A	DIN 43531 A	DIN 43531 A	DIN 43531 A	DIN 43531 A	DIN 43531 A	DIN 43531 A	DIN 43531 A	DIN 43531 A	DIN 43531 A
6.04	Battery voltage/capacity at 5-hour discharge	V/Ah	48V/500Ah	48V/500Ah	48V/625Ah	48V/500Ah	48V/750Ah	48V/750Ah	48V/750Ah	48V/625Ah	48V/750Ah	48V/750Ah	48V/750Ah
6.05	Battery weight	kg	715	715	855	855	1025	1025	855	855	855	1025	1025
6.06	Energy consumption according to VDI 60 cycle	kWh/h	-	-	-	-	-	-	-	-	-	-	-
Miscellaneous													
8.01	Type of drive control		AC transistor	AC transistor	AC transistor	AC transistor	AC transistor	AC transistor	AC transistor	AC transistor	AC transistor	AC transistor	AC transistor
8.02	Maximum operating pressure for attachments	bar	181	181	181	181	181	181	181	181	181	181	181
8.03	Oil flow for attachments	l/min	-	-	-	-	-	-	-	-	-	-	-
8.04	Noise level, value at operator's ear (EN 12053)	dB(A)	66	66	66	66	66	66	67	67	67	67	67
8.05	Towing coupling design / DIN type, ref.		15170/H	15170/H	15170/H	15170/H	15170/H	15170/H	15170/H	15170/H	15170/H	15170/H	15170/H

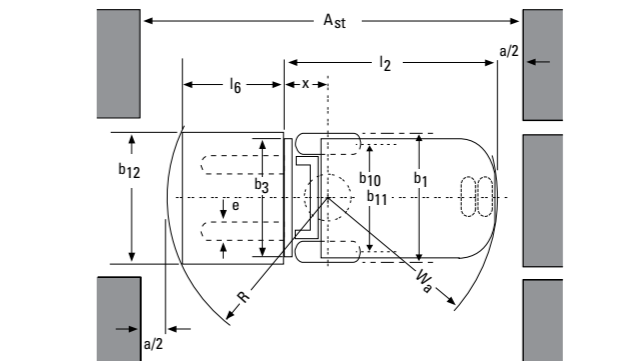
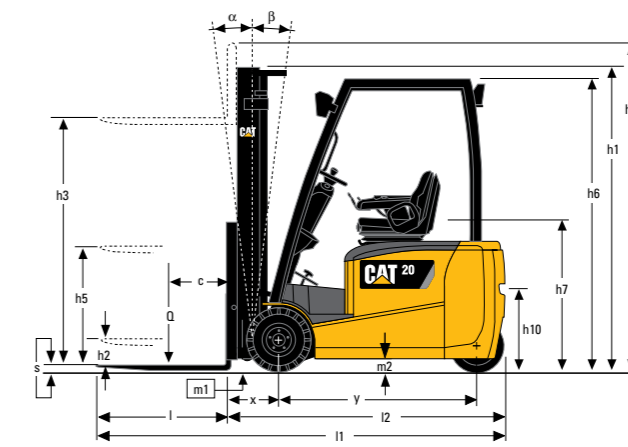

$Ast = Wa + R + a$
 $Ast =$ Working aisle width
 $Wa =$ Turning radius
 $a =$ Safety clearance = 2 x 100 mm
 $R = \sqrt{(l6 + x)^2 + (b12 / 2)^2}$
 $l6 =$ Pallet length (800 or 1000 mm)
 $b12 =$ Pallet width (1200 mm)

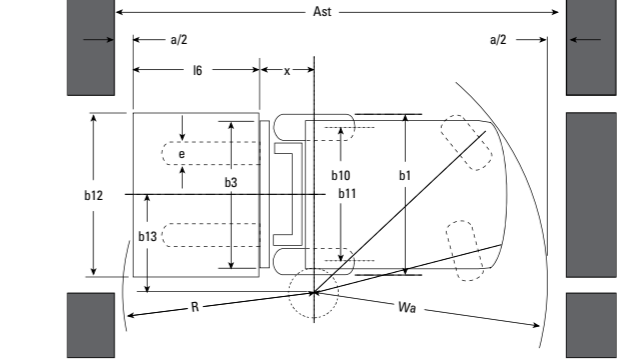
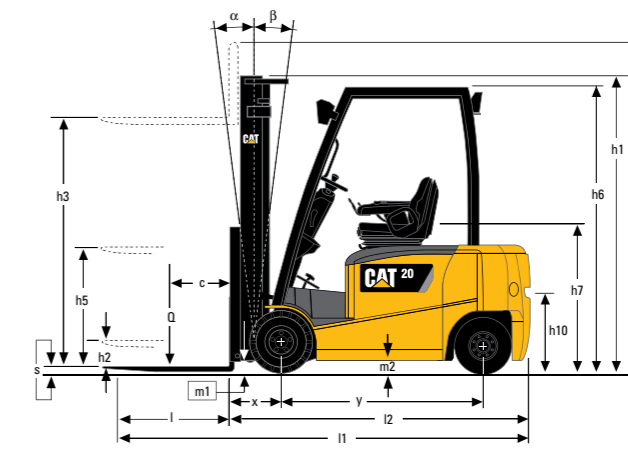

$Ast = Wa + x + l6 + a$
 $Ast =$ Working aisle width with load
 $a =$ Safety clearance (200 mm)
 $l6 =$ Pallet length (800 or 1000 mm)
 $b12 =$ Pallet width (1200 mm)

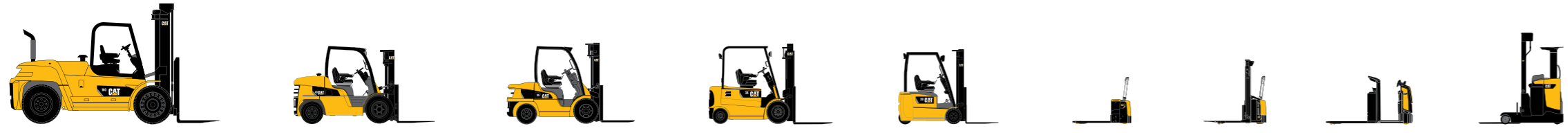

Lower Cost of Ownership

- 5 preset performance settings allowing operator to match the truck to all situations.
- Electric 'Steer-by-wire' system, with force feedback requires no hydraulics (3 wheel models) and reduces energy consumption.
- 1,000 hour service intervals and short maintenance routines reduce total cost of operation and give maximum 'up-time'.
- 'Maintenance-free' brakes and LED lights.
- Advanced AC technology provides fast lift and travel speeds for quicker work cycles.
- MicroCommand® AC controller gives programmable performance and energy savings.
- Profile tubed overhead guard allows simple application of panel cabins.
- Accommodates both DIN and BS size batteries.

Safety and Ergonomics

- PDS+ (Presence Detection System) prevents accidental operation when driver not seated. Now includes 'ramp hold' and electric automatic park brake.
- Back-up handle with horn button.
- Intuitive Speed Control contributes to safer operation when cornering.
- Automotive pedal layout for intuitive operation.
- Fully adjustable suspension seat.
- 'Maintenance-free' brakes and LED lights.
- Operator is kept informed with key operational information at all times by the multi function display.
- Low, deep, wide step for comfortable on/off access.
- Large, uncluttered floorspace for optimum comfort and safe operation of pedals.
- Modern, smooth exterior styling and comfortable operator compartments

Unmatched Productivity

- 'Maintenance-free' wet disc brakes that allow the truck to be operated in contaminated areas/applications.
- Very bright LED working lights give improved visibility in confined areas.
- Easy access to all components, contributing to quicker maintenance.
- Multi function display shows relevant information and error codes.
- Diagnostics can be easily accessed via Laptop.
- Heavy duty chassis and rigid masts.
- Strong regenerative braking speeds up working cycles.
- Large battery hood opening for wide, easy access.
- Optional sideway battery exchange allows fast, safe switching in multiple shifts.
- IPx4 protects components from water ingress coming from all-angles allowing operation in outside applications and wet environments.

Options

- Weight indicator
- Easy to use manual control hydraulic levers
- High visibility overhead guard
- Factory supplied panel cabin packages
- Quick sideway battery exchange
- Variety of fork lengths available
- Wide range of mast alternatives