

# Material Handling Arm

for Skid Steer and Multi Terrain Loaders



## Features

High strength tubular steel construction

Light rigid design

Maximum effective reach

## Benefits

Optimal performance in lifting applications.

Ensures maximum load lifting capacity when required.

Ability to operate in difficult and varied applications.

# Material Handling Arm

## Specifications and Dimensions

	mm
<b>A</b> Width (Excl side step)	1156
<b>B</b> Width (Incl side step)	1319
<b>C</b> Height	1473
<b>D</b> Reach	753

Max Rated Load of Worktool is 900kg

Operating Load is dependent on Machine refer to machine OMM for details on Rated Loads for Specific Tool/machine combinations

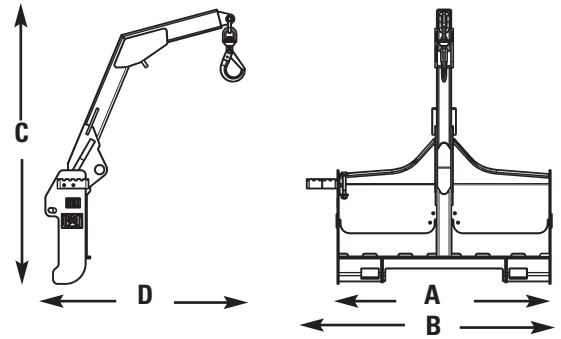
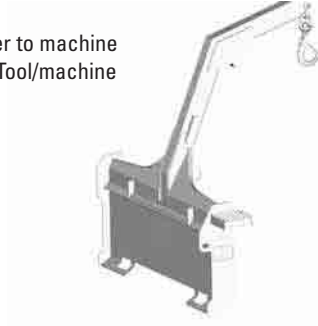

## Matching Guide

### Material Handling Arm

### Skid Steer Loaders

216B, 226B, 232B, 236B,  
242B, 246C, 248B, 256C, 262C, 272C

### Multi Terrain Loaders

247B, 257B, 277C  
287C, 297C