

# Wheel Saws

for Skid Steer, Multi Terrain, Compact Track and Compact Wheel Loaders



*For cutting trenches in concrete, asphalt and hard rocky ground for laying cables and pipes.*

## Features

Direct drive system features a hydraulic piston pump motor

Hydraulic side shift and depth control, standard on all models

Trench cleaning device is hydraulically operated

Interchangeable cutting tips

Deflector plates

## Benefits

Ensures maximum cutting rate and wheel torque.

Allows for cutting close to curbs, walls and other obstructions and minimizes the need to reposition the machine.

Blade can be controlled up and down to remove spoil and ensure a clean trench.

Easily serviced.

Left or right discharge of spoil.

# SW45, SW60 Wheel Saws

## Specifications and Dimensions

		SW45	SW45	SW45	SW60	SW60
<b>A</b> Overall Width	mm	1803	1803	1803	1866	1866
<b>B</b> Maximum Wheel Width	mm	<b>80</b>	<b>160</b>	<b>200</b>	<b>160</b>	<b>200</b>
<b>C</b> Overall Height	mm	1400	1435	1435	1746	1746
<b>D</b> Overall Length	mm	1992	1992	1992	2230	2230
Weight	kg	1041	964	997	1151	1168
Trench Cleaning Device		No	Yes	Yes	Yes	Yes
Drive Method		Piston Motor/Planetary				
Required Hydraulic Flow	L/min	90-160	90-160	90-160	100-160	100-160
Optimal Hydraulic Pressure	bar	180-300	180-300	180-300	180-300	180-300
Wheel Torque at Maximum Pressure	Nm	6703	6703	6703	8041	8041
Wheel Speed at Maximum Flow	rpm	115	115	115	96	96
Bit Speed at Maximum Flow	mpm	439	439	439	458	458
Conical Bits	per wheel	64	56	62	96	96
Maximum Depth of Cut	mm	450	450	450	600	600
Sideshift Travel	mm	650	650	650	650	650
Bit Type		Standard: Concrete Optional: All Purpose				

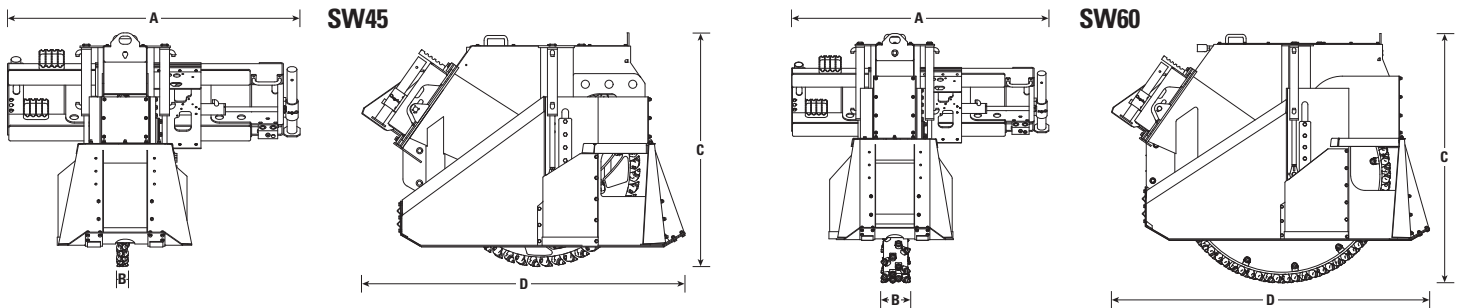

## Hydraulic Requirements

High flow hydraulics and full electrics.

## Matching Guide

Wheel Saws	Skid Steer Loaders	Multi Terrain Loaders	Compact Track Loaders
SW45	226B, 242B, 246C, 256C, 262C, 272C	257B, 277C, 287C, 297C	279C, 289C, 299C
SW60	256C, 262C, 272C	277C, 287C, 297C	279C, 289C, 299C
	Compact Wheel Loaders		
SW45	906H, 907H, 908H		
SW60	906H, 907H, 908H		

For more complete information on Cat products, dealer services, and industry solutions, visit us on the web at [www.cat.com](http://www.cat.com)

HEHX3178-3 (10/2008) hr

© 2008 Caterpillar -- All Rights Reserved

Materials and specifications are subject to change without notice. Featured machines in photos may include additional equipment. See your Caterpillar dealer for available options.

CAT, CATERPILLAR, their respective logos, "Caterpillar Yellow" and the POWER EDGE™ trade dress, as well as corporate and product identity used herein, are trademarks of Caterpillar and may not be used without permission.

**CATERPILLAR**®  
TODAY'S WORK. TOMORROW'S WORLD.™