

730

Articulated Truck



Engine

Engine Model	Cat® C11 ACERT™	
Gross Power – SAE J1995	242 kW	325 hp
Net Power – SAE J1349	237 kW	317 hp

Weights

Rated Payload	28.1 tonnes	31 tons
---------------	-------------	---------

Body Capacities

Heaped SAE 2:1	16.9 m ³	22.1 yd ³
----------------	---------------------	----------------------

730 Articulated Truck

The 730 Caterpillar® Articulated Truck is a world-leading earthmoving solution.

Cat® C11 Engine with ACERT Technology

- ✓ The core concept behind ACERT technology is advanced combustion. ACERT engine technology carefully controls the combustion process to reduce pollutant levels while maintaining performance and efficiency. **pg. 4**

Performance and Productivity – Power Train

- ✓ The Cat C11 ACERT engine, matched with the six-speed electronic controlled transmission and a powerful retarder, delivers the performance needed to get the job done. **pg. 5**

Performance and Productivity – Suspension and Traction Control

Three-point front suspension provides a smooth ride, allowing the operator to travel at speed over rough terrain. Cross-axle differential locking system provides full driveline locking for maximum performance in adverse conditions. **pg. 6**

Serviceability

Long service intervals and easy maintenance provide better machine availability, resulting in lower owning and operating costs. **pg. 10**

Complete Customer Support

Your Cat dealer offers a wide range of services that can be set up under a customer support agreement when you purchase your equipment. The dealer will help you choose a plan that can cover everything from machine configuration to eventual replacement. **pg. 11**

The 730 offers proven reliability and durability, high performance, low fuel consumption, operator comfort and low operating costs.



Operator Comfort

- ✓ Large center-mounted cab, oscillating front axle, air suspension seat, full-size trainer seat and large storage space provide exceptional operator comfort. **pg. 7**

Ease of Operation

- ✓ Ergonomically designed wrap-around dash, tilt and telescopic steering wheel, easy-to-reach controls and outstanding all-around viewing promote fast, confident machine operation. **pg. 8**

Durability and Reliability

The 730 has built-in durability and reliability. Cat purpose-built, articulated truck drivetrain components, front frame and hitch ensure maximum performance in the toughest applications. **pg. 9**



✓ *New Feature*

Cat C11 Engine with ACERT Technology

A combination of proven systems and innovative new technologies, ACERT engines optimize performance while meeting EPA Tier 3 and EU Stage IIIa engine exhaust emission regulations.



ACERT Technology. The Cat C11 ACERT engine introduces a series of evolutionary, incremental improvements that provide breakthrough engine technology built on systems and components developed by Caterpillar with proven reliability. The technology capitalizes on Caterpillar expertise in four core engine systems: fuel, air, electronics and after treatment. ACERT technology is a unique and revolutionary systems solution that enables Cat engines to meet today's clean air regulations, thus establishing the building blocks for attaining tomorrow's more stringent standards.

C11 Block. The one-piece, gray iron block features generous ribbing for stiffness and heavy bearing bulkheads for rigidity and strength as the crankshaft turns. Straight O-ring connection points reduce the loss of engine oil and fluids.

Cylinder Head and Piston Technology.

The C11 has a cross-flow cylinder head with refined port geometry, which improves breathing and provides better combustion. The Monotherm/steel pistons have a forged steel design, which offers high strength, light weight and tighter tolerances. The result is better oil control, minimal blow-by and long liner life.

Advanced Diesel Engine Management (ADEM) A4 Engine Controller.

The ADEM A4 electronic control module manages fuel delivery to get the best performance per liter or gallon of fuel used. The engine management system provides flexible fuel mapping, allowing the engine to respond quickly to varying application needs. It tracks engine and machine conditions while keeping the engine operating at peak efficiency.

Fuel Delivery. Multiple injection fuel delivery involves a high degree of precision. Precisely shaping the combustion cycle lowers combustion chamber temperatures, generating fewer emissions and optimizing fuel combustion. This translates into more work output for your fuel cost.

Noise Reduction Technologies.

Noise reduction has been achieved through design changes to the isolated top cover, oil pan, multiple injection strategy, insulated timing case cover, sculpted crankcase and gear train refinements.

Performance and Productivity – Power Train

Integrated power train with more power, greater performance and lower fuel consumption.

Mechanically Actuated Electronic Unit Injection (MEUI). A highly evolved fuel system with a proven record of reliability in the field. It combines the technical advancement of an electronic control system with the simplicity of direct mechanically controlled unit fuel injection. It excels in its ability to control injection pressure over the entire engine operating speed range. These features allow the C11 to have complete control over injection timing, duration and pressure.

Air-to-Air Aftercooling (ATAAC). ATAAC keeps air intake temperatures down and, in concert with the tight tolerance combustion chamber components, maximizes fuel efficiency and minimizes emissions. Significant improvements in airflow are generated by a turbocharger, unique cross-flow head and a single overhead camshaft.

Wastegate Turbocharging. Single wastegate turbocharger provides higher boost over a wide range, outstanding low-end performance with improved peak torque and enhanced engine response.

Electronic Transmission. The Caterpillar six-speed electronically controlled transmission is designed specifically for the articulated truck and its applications. It features anti-hunt shift strategy for speed continuity.

Electronic Clutch Pressure Control. ECPC technology works with the Controlled Throttle Shifting to manage shift torque and provide exceptional shift smoothness.

Controlled Throttle Shifting (CTS). Significantly reduces power train stress and clutch wear by controlling engine speed, torque converter lock-up and transmission clutch engagements.



Engine Overspeed Inhibitor. Electronic Transmission Control (ETC) protects against engine overspeeding by shifting the transmission up one gear at specified rpm settings. If the transmission is in its highest gear, torque converter lockup disengages.

Directional Shift Management. Regulates engine speed during directional shifts to prevent damage caused by high-speed directional changes.

Programmable Top Gear Selection. Electronic Transmission Control lets you electronically limit top gear selection without the use of additional service tooling or mechanical limiting of the shift cane.

Retarder. Integral retarder with high-power density design. Due to its compact size, the unit quickly fills with oil, providing more retarding power and fast response times.

Retarder Power. Increased power capability gives operators greater control on short, steep grades and minimizes the need to apply the brakes, resulting in extended service brake life.

Hydraulic Fan. The remote-mounted hydraulic fan is temperature sensitive providing variable speeds when needed, which minimizes power requirements. The result is more power to the ground and faster cycle times.

Performance and Productivity – Suspension and Traction Control

Suspension systems and traction control – delivering power to the ground in all conditions.

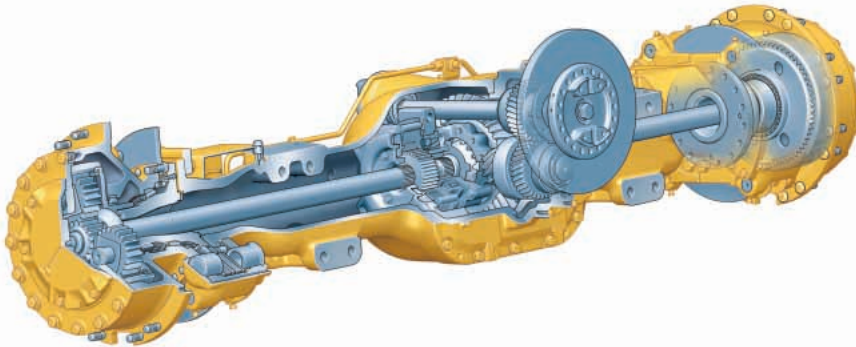

Front Suspension. Three-point front suspension oscillates $\pm 6^\circ$ to provide a smooth ride, allowing the 730 to travel at speed over rough terrain and softening impact loads on structures and components.

A-Frame Construction. The front suspension uses an oscillating A-frame with a lateral tie rod to control axle sideways movement.

Front Suspension Cylinders. Cylinders are designed for tough applications and offer a soft, smooth ride.

Mounting Points. Suspension mounting points are integrated into the axle housing, increasing reliability.

Rear Suspension. Features a walking beam geometry with Caterpillar designed rear suspension mounts which provide a reliable and stable ride for excellent load retention.

Traction Control. Traction control is comprised of a wet clutched inter-axle differential and wet clutched cross-axle differentials. All differentials can be engaged and disengaged on-the-go for maximum versatility. When used together, the differentials provide 100 percent driveline locking.

Inter-axle Differential Lock. Locks all three axles in unison and modifies torque distribution for excellent traction in poor underfoot conditions and on grades. It is operated by a switch located in the footrest.

Cross-axle Differential Locks. Provides full driveline locking – all three axles and all six wheels for maximum performance in the most adverse conditions. Acts in unison with the inter-axle differential lock when the footswitch is actuated and the dash-mounted switch is selected.

Fast Hoist Cycle Times. Fast body raise and lower times mean less time spent in the dump area.

Load-Carrying Capacity. Large target area provides high-load carrying capacity. Its diverging flow design gives clean load ejection, which maximizes production and avoids waste of material carry-back.

Exhaust Heat System. The body comes exhaust heat ready.

Steering System. Cat articulated trucks use a load-sensing steering system for smooth, precise control. It features a single, variable displacement pump. Two double-acting, cushioned steer cylinders allow the machine to articulate 45° to the left or right, permitting precise positioning in tight areas. Its compact Hand Metering Unit controls the cylinder for responsive steering and performance. An electronic secondary steering system is standard.

Hydraulic Steering Cushioning System. The 730 incorporates a hydraulic cushioning system, resulting in smooth, responsive steering, operator comfort and reduced shock loads to the machine components.

Operator Comfort

The operator's office – high productivity from a comfortable, motivated operator.



Ride Comfort. The three-point front suspension with its oscillating axle and low pressure ride struts, combined with the center-mounted cab, offers unrivaled levels of ride comfort for the operator in all driving conditions. The operator remains comfortable and productive throughout the day.

Spacious Two-Person Cab. The 730 features a large two-person cab, offering comfortable working space for both the operator and trainer or trainee. All 700 Family articulated trucks use the same spacious cab design.

Air Suspension Seat. The air suspension seat enhances operator comfort with a cushioned upper high back, adjustable damping with three settings, ride zone indicator and adjustable lumbar settings. It is fully adjustable to provide the optimal driving position.

Storage Space. Plenty of storage space to create a secure and uncluttered working environment.

Trainer Seat. Full-size trainer seat features a fully padded seat with a backrest and a wide, retractable seatbelt for a secure and comfortable ride. The trainer seat is positioned next to the operator seat, giving both the operator and trainer a clear view of the instrument panel, controls and the road.

Heating/Ventilation/Air Conditioning. Twelve vents provide air distribution to keep the operator comfortable and to provide rapid defrosting of all windows. Heating and air conditioning are standard and the recirculation filter is positioned for easy servicing.

Radiator Mounting. The radiator is mounted at an angle to prevent heat transfer to the cab.

Dual-Sliding Window. The right-hand window is a dual-sliding window. Opening this window with the left rear-hinged window provides cross-flow ventilation and enhanced operator comfort.

Sound Levels. Cab mounts are designed to reduce noise and vibration in the cab. All connections to the cab are resiliently mounted. The operator's station makes extensive use of sound absorbing and barrier materials to keep sound levels low.

Ease of Operation

Designed for simple, easy operation, the 730 allows the operator to focus on production.



Ergonomic Layout. The controls and layout of the cab are designed to make it as easy to operate as your car. Quick and easy to read and simple to operate, the controls and gauges on the 730 allow the operator to concentrate on production.

Dash. The Generation II wrap-around dash puts all controls within easy reach of the operator. Featuring LED illuminated rocker switches, large LCD display and a rear wash wipe rocker switch. It provides an automotive feel with the industrial strength you would expect from Caterpillar.

Viewing Area. The low sloping hood and placement of the cooling package behind the cab give the operator excellent all-around visibility. The large glass area and central operator position also provide excellent visibility.

Wipers. The wet arm wiper system cleans more glass area and is bottom-mounted to keep it out of the operator's line of sight. Windows are tinted to reduce glare.

Differential Lock Controls. The switch for the inter-axle differential lock is positioned in the operator's footrest for ease of operation. A dash-mounted switch is all that is required to select full driveline lock-up. Disengaging the foot switch opens all differential locks immediately.

Transmission and Hoist Levers.

The hoist lever provides easy, comfortable operation. The transmission lever offers excellent comfort, along with the control for top gear limit, transmission hold and neutral lock.

Suspended Pedals. Easy to operate and reach with plenty of leg and foot room. Suspended pedals also make it easier to clean the cab floor by keeping the pedals out of the dirt.

Cat 2S Monitoring System. Provides an improved method of monitoring critical machine functions and alerts the operator to an immediate or impending problem. The system provides four levels of warning.

Durability and Reliability

High availability leads to high productivity.

Front Frame. The front frame design features a large box-section, and wide, stiff frame beams to handle torque loads. The divergent frame design decreases stress in the hitch area and optimizes suspension geometry. The frame has been designed to make maximum use of robotic welding for increased durability.

Rear Frame. Twin-box construction minimizes stress concentration and provides low weight with long service life.

Castings. The front and rear frames make extensive use of heavy-duty steel castings to handle stress concentrations.

Front Suspension. Three-point front suspension provides unparalleled ride quality. It also protects the truck from the most adverse road conditions by absorbing shock loads that would otherwise reach the frame.

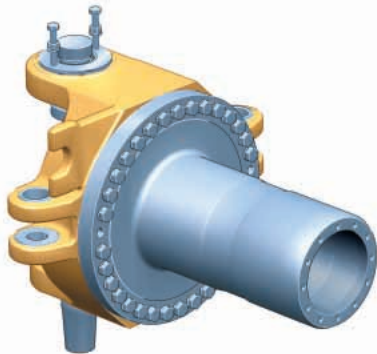
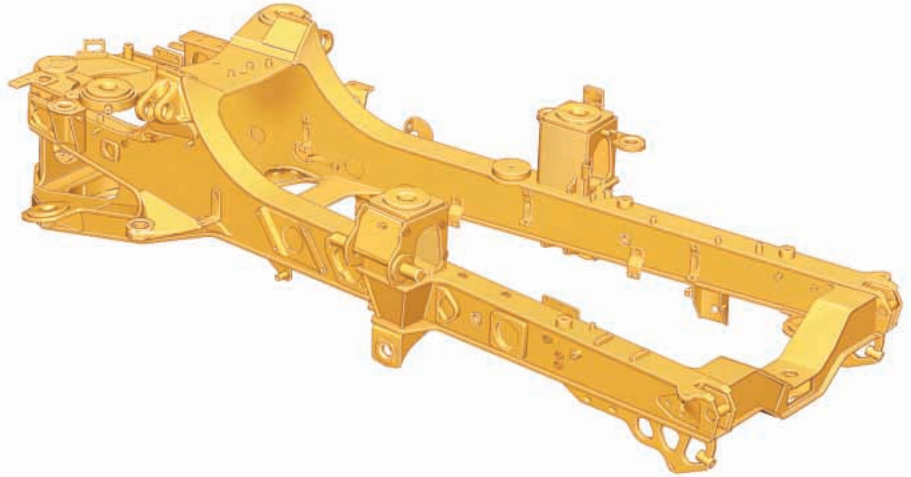

Articulating/Oscillating Hitch.

The articulating hitch provides the truck with steering articulation and the oscillation ensures the truck maintains all-wheel ground contact in rough terrain.

Steer Cylinders In-Line with Hitch.

Steer cylinders are in-line with the hitch, minimizing steer loads and stress in the hitch area.

Hitch Construction. Two-piece hitch construction features a strong, durable cast steel head bolted to a hard wearing forged steel tube. The hitch tube has large, hardened bearing areas and a hardened thrust face for reduced maintenance and longer life.

Service Brakes. Features a dual-circuit, all-wheel system. Full-power hydraulic system actuates self-cleaning caliper disc brakes with independent front and rear circuits and accumulators.

Parking Brake. Located on the center axle in an elevated position out of the dirt and designed to deliver high heat capacity and abuse resistance.

Cat Power Train Components. The 730 features purpose-designed earthmoving components from the engine through to the final drives. Proven in articulated trucks and other Cat equipment, these rugged building blocks ensure long life and reliability.

Radiator Protection. The radiator is located behind the cab for excellent visibility. This design incorporates three levels of protection:

- 1) Body Spill Guard.**
- 2) Cab Steel Spill Guard.**
- 3) High-Strength Surround.**

Serviceability

More time on production, less time and money spent on servicing.



Long Service Intervals. Long engine oil change and hydraulic oil change intervals lower maintenance costs and downtime. Wheel-bearing adjustment is completely eliminated.

Lube Points. Lube points are grouped at the rear of the front frame and the front of the rear frame. Universal joints are lubed for life, eliminating servicing. Autolube is optional.

Service Points. Engine and transmission dipstick and fill caps, air and fuel filters, and the fuel priming pump are all mounted on the left side of the engine under the hood. Coolant level indicator and fill caps are outside the cab.

Radiator. The radiator package is located behind the cab, which provides protection from frontal impacts and offers access to both inlet and outlet sides of the radiator.

Extended Life Coolant. Extends the change interval and improves water pump life by reducing aluminum corrosion.

Hood. The hood is raised and lowered electrically requiring minimal operator effort when servicing.

Electrical Service Center. Located inside the cab, this service center provides a power port, diagnostic connector and the Cat Data Link connector.

Cat Data Link Connector. Provides a connection point for a laptop computer running Electronic Technician (ET) software. The Cat Data Link port performs programming functions on all electronic controls.

Service Access. The cab tilts to the side to provide easy access underneath, which simplifies servicing of the transmission, drive shafts and hydraulic pumps. Machine electrical and hydraulic interfaces are located on the right side of the cab, behind a removable cab body panel for easy access.

Integrated Transmission Package.

The transmission integrates the transmission pump, torque converter and four pump drives into a single package. Because the transmission is an integral design, it eliminates many of the external hoses, resulting in less servicing and higher reliability.

Engine and Transmission Removal.

The front frame design allows the engine and transmission to be removed and installed in one piece.

Truck Transport. The suspension system eliminates the need to lower the suspension when transporting the truck, reducing maintenance and downtime.

Output Transfer Gear. Provides lubrication of all bearings and clutches using a distributed-pressure lubricated and filtered system. Good lubrication translates into less service and repair.

Complete Customer Support

Cat dealer services help you operate longer with lower costs.

Selection. Make detailed comparisons of the machines you are considering before you buy. What are the job requirements, machine attachments and operating hours? What is your need for machine availability and do you need or have the proper loading tool match? Your Cat dealer can help.

Custom Products. The 730 is compatible with a wide range of Caterpillar and auxiliary equipment manufacturers' specialized products. For more information, contact your local Cat dealer.

Purchase. Look past initial price, look at the value the 730 offers. Consider the resale value, compare productivity and day-to-day operating costs and fuel consumption. Consult your local Cat dealer for financing options.

Loading Tool Match. An optimum system match gives you a major productivity advantage. The 730 is an excellent match for the Cat 345B II and 330C Hydraulic Excavators; and Cat 972G II, 966G II, 962G II and 950G II Wheel Loaders. This results in increased production and lower system costs per unit of volume moved.

Operation. For the best operating techniques to increase productivity and your profit, turn to your Cat dealer for the latest training literature and trained staff.

Maintenance. Repair option programs guarantee the cost of repairs up front. Diagnostic programs such as S•O•SSM and Technical Analysis help you avoid unscheduled repairs.



Replacement. Repair or rebuild? Cat articulated trucks are designed for a longer life with rebuildable components. Your Cat dealer can help you evaluate the cost involved so you can make the right choice.

Product Support. The 730 offers easy maintenance with combined service points and extended service intervals to keep the machine running longer. Your local Cat dealership offers unsurpassed worldwide parts support, trained technicians and customer support agreements.

Warranty. Your local Cat dealer is there to support and protect you. Extended warranty options are also available.

www.cat.com. For more complete information on Cat products, dealer services and industry solutions, visit us on the Web at www.cat.com.

Engine

Engine Model	Cat® C11 ACERT™	
Gross Power – SAE J1995	242 kW	325 hp
Net Power – SAE J1349	237 kW	317 hp
Net Power – ISO 9249	239 kW	321 hp
Net Power – EEC 80/1269	239 kW	321 hp
Flywheel Power	237 kW	317 hp
Bore	130 mm	5.1 in
Stroke	140 mm	5.5 in
Displacement	11.15 L	680 in ³

- The power ratings apply at rated speed of 1,800 rpm when tested under the conditions for the specified standard.
- The net power advertised is the power available at the flywheel when the engine is equipped with alternator, air cleaner, muffler and fan at minimum speed.
- Net power when the fan is at maximum speed is 225 kW (302 hp) per the SAE reference conditions.
- The 730 meets EPA Tier 3/EU Stage IIIa emission specifications for the U.S. and Europe through 2010.
- No engine derating required below 3048 m (10,000 ft).

Weights

Rated Payload	28.1 tonnes	31 tons
---------------	-------------	---------

Body Capacities

Heaped SAE 2:1	16.9 m ³	22.1 yd ³
Struck	13.1 m ³	17.1 yd ³
Heaped SAE 1:1	20.6 m ³	26.9 yd ³

Transmission

Forward 1	7.64 km/h	4.75 mph
Forward 2	14.43 km/h	8.97 mph
Forward 3	21.95 km/h	13.64 mph
Forward 4	33.63 km/h	20.9 mph
Forward 5	46.82 km/h	29.1 mph
Forward 6	55.3 km/h	34.37 mph
Reverse 1	8.48 km/h	5.27 mph

Sound Levels

Interior Cab	76 dB(A)
--------------	----------

- The operator sound exposure Leq (equivalent sound pressure level) measured according to the work cycle procedures specified in ANSI/SAE J1166 OCT 98 is 76 dB(A), for the cab offered by Caterpillar, when properly installed and maintained and tested with the doors and windows closed.
- Hearing protection may be needed when operating with an open operator station and cab (when not properly maintained or doors/windows open) for extended periods or in noisy environments.

Operating Weights

Front Axle – Empty	13 140 kg	28,969 lb
Center Axle – Empty	5000 kg	11,023 lb
Rear Axle – Empty	4710 kg	10,384 lb
Total – Empty	22 850 kg	50,376 lb
Front Axle – Rated Load	2720 kg	5,997 lb
Center Axle – Rated Load	12 700 kg	27,999 lb
Rear Axle – Rated Load	12 700 kg	27,999 lb
Total – Rated Load	28 120 kg	61,994 lb
Front Axle – Loaded	15 860 kg	34,965 lb
Center Axle – Loaded	17 700 kg	39,022 lb
Rear Axle – Loaded	17 410 kg	38,382 lb
Total – Loaded	50 970 kg	112,370 lb

Body Plate Thickness

Front	8 mm	0.31 in
Scow	14 mm	0.55 in
Side	12 mm	0.47 in
Base	14 mm	0.55 in

Service Refill Capacities

Fuel Tank	360 L	95 gal
Cooling System	86 L	22.7 gal
Hydraulic System	100 L	26.4 gal
Engine Crankcase	37 L	9.8 gal
Transmission	36 L	9.5 gal
Final Drives/Differential	132 L	34.9 gal
Output Transfer Gear Box	18 L	4.8 gal

Body Hoist

Raise time	12 Seconds
Lower time	8 Seconds

Standards

Brakes	SAE J/ISO 3450:1998
Cab/FOPS	SAE J231:JAN81 and ISO 3449:1992 Level II
Cab/ROPS	SAE J1040 May 1994 and ISO 3471:1994
Steering	ISO 5010 1992E

Dimensions

Wheel base between back tires	1700 mm	5 ft 9 in
-------------------------------	---------	-----------

Dimensions

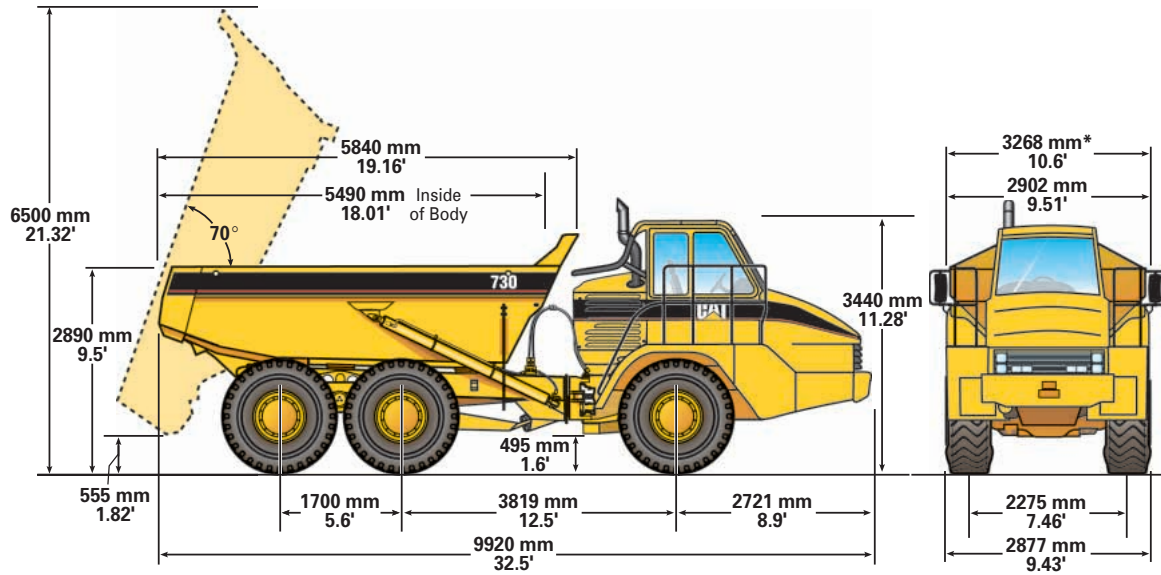

* if equipped with a scissor tailgate

Turning Circle

Dimensions are for machines equipped with 23.5R25 tires.

Turning dimensions

Steer angle — left/right	45°
SAE turning radius	7254 mm 286 in
Clearance radius	7605 mm 300 in
Inside radius	3710 mm 146 in
Aisle width	4980 mm 196 in

Steering

Lock to Lock 4.75 seconds @ 60 rpm

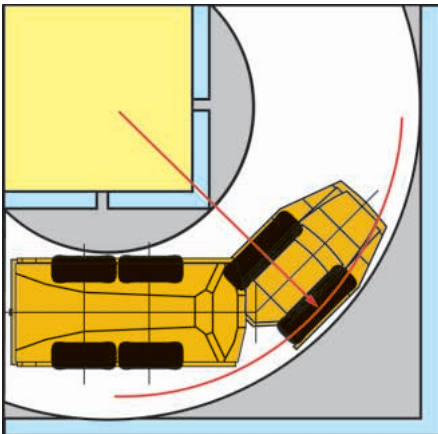

Optimal Loader/Truck Pass Matching

Hydraulic Excavators	345B II	330C
Passes	4-5	5-6

Wheel Loaders	972G II	966G II	962G II	950G II
Passes	3-4	4	4-5	5

An optimum system match gives you a major productivity advantage. The 730 is an excellent match for the Cat 345B II, and 330C Hydraulic Excavators; and Cat 972G II, 966G II, 962G II and 950G II Wheel Loaders. This results in increased production and lower system costs per unit of volume moved.

Gradeability/Speed/Rimpull

To determine performance, read from Gross Weight down to % Total Resistance. Total Resistance equals actual % grade plus 1% for each 10 kg/metric ton (20 lb/ton) of Rolling Resistance. From this point, read horizontally to the curve with the highest attainable speed range. Then, go down to Maximum Speed. Usable Rimpull depends on traction available.

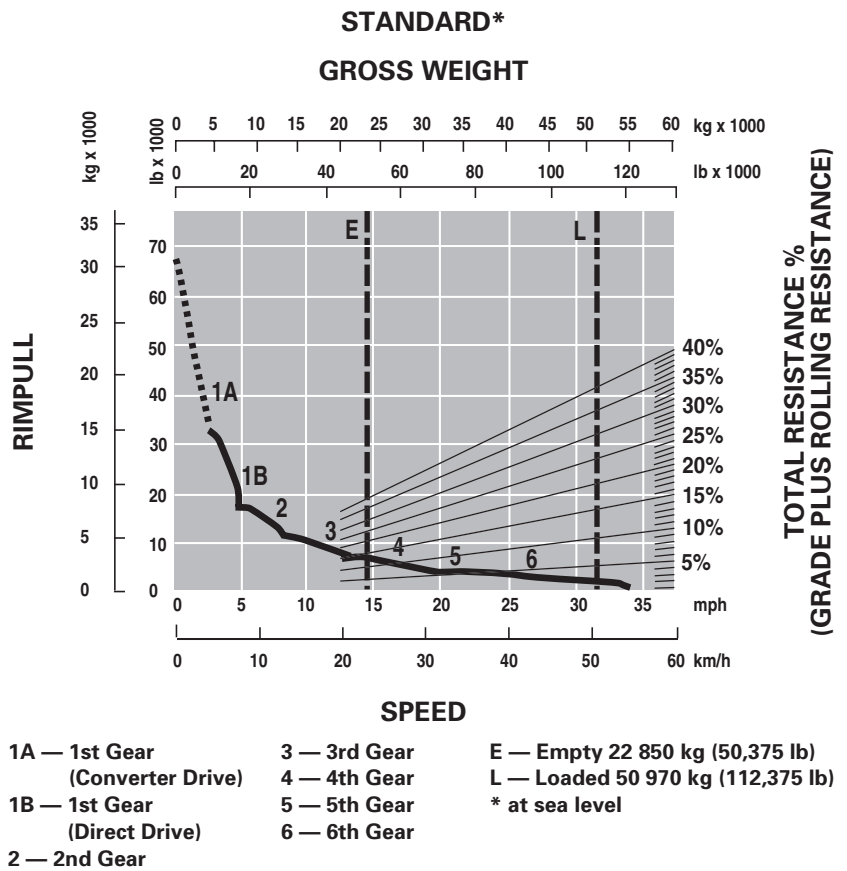

Retarding Performance

To determine performance, read from Gross Weight down to % Effective Grade. Effective Grade equals actual % favorable grade plus 1% for each 10 kg/metric ton (20 lb/ton) of Rolling Resistance. From this point, read horizontally to the curve with the highest attainable speed range. Then, go down to Maximum Speed. Retarding effect on these curves represents full application of the retarder.

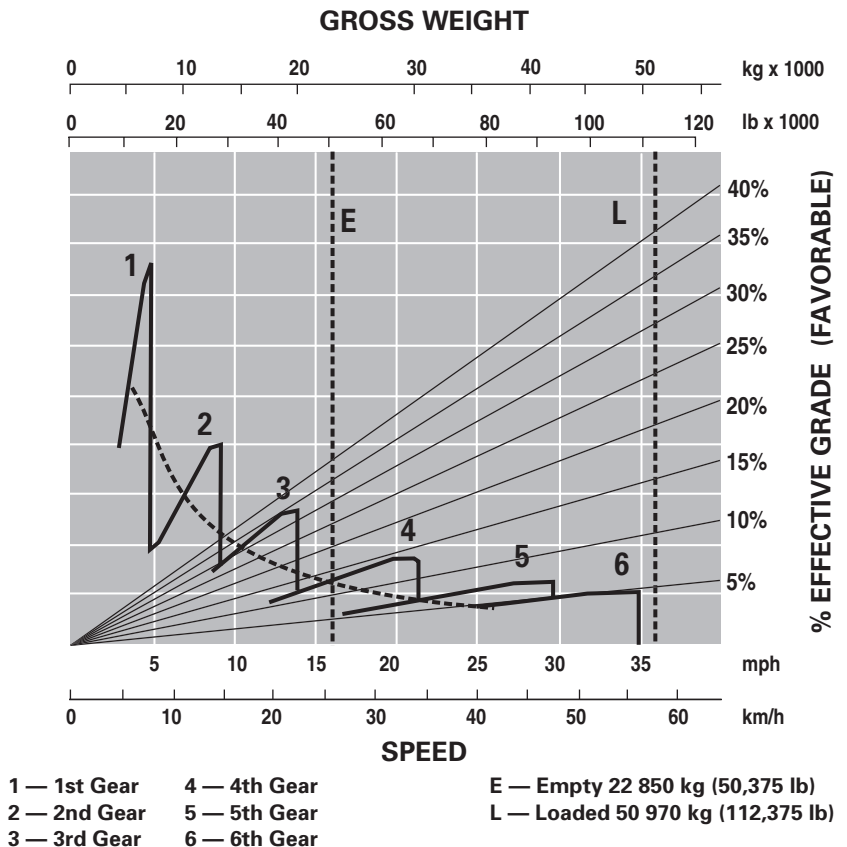

Standard Equipment

Standard equipment may vary. Consult your Caterpillar dealer for details.

- Air conditioning with R134A refrigerant
- Air vents, adjustable
- Auto shift six-speed transmission
- Back up alarm
- Body, adapted for exhaust heat
- Cat C11 engine with ACERT Technology
- CD Radio ready
- Differentials, standard with clutched cross-axle differential locks for all axles
- Dual circuit caliper disc brakes
- Electrical system, 24 volt, 5A 24- to 12-volt converter
- Electro hydraulic hoist control
- Glass windows, laminated and tinted (front), toughened and tinted (rear)
- Guards: rear window, radiator, crankcase and axle
- Headlights, four
- Heater and defroster with four-speed fan
- Horn, electric
- Lights: cab interior, front, side, rear, two reversing/working lights, two stop/tail lights, front and rear direction indicators
- Mirrors, main and auxiliary, left and right
- Mud flaps, wheel arch and body mounted
- Retarder
- ROPS/FOPS cab, with full instrumentation, including:
 - Instrument cluster display module
 - Indicator lamps: left turn, secondary steering, primary steering loss, front and rear brake temp (735/740 and 740 Ejector only), brake oil pressure, action lamp, transmission fault, park brake, charging system status, differential lock, body not in float, right turn, high beam, transmission hold, machine filter warning, retarder, retarder up shift warning
 - Gauges: engine oil pressure, engine coolant temperature, tachometer, torque converter oil temperature, fuel level, fuel tank level gauge.
 - Meters: service hour meter, speedometer, tachometer
- Seat, fully adjustable, air suspension
- Seat, padded companion/trainer
- Seat belts, two retractable
- Secondary steering
- S•O•SSM sampling valves
- Spill guard, front, integral part of fabricated body
- Starting receptacle, electric, remote
- Storage: two cup holders, flask receptacle, under seat storage, door pocket, behind seat storage, coat hook.
- Sun visor
- Three axle, six-wheel drive
- Tilt and telescopic steering wheel
- Tires, six 23.5R25, radial
- Tow pins front and rear
- Vandalism protection: lockable caps for fuel tank and hydraulic oil tank
- Windows opening side, tinted
- Windshield wiper and washer, two speed, intermittent (front)
- Windshield wiper and washer, two speed (rear)

Optional Equipment

Optional equipment may vary. Consult your Caterpillar dealer for details.

Autolube installation for automatic greasing of bearings
Body connection for exhaust heat
Body liners
CD Receiver
Cold weather start attachment
Cycle counter/operator monitoring kit
Fast fuel fill

Flashing Beacon
Heated rearview mirrors
Product Link, Radio and Worldwide
Rearview Camera
Tailgate:
– Scissor-type

Notes

730 Articulated Truck

AEHQ5647-01 (7-06)

Replaces AEHQ5647

For more complete information on Cat products, dealer services,
and industry solutions, visit us on the web at www.cat.com

© 2006 Caterpillar
All Rights Reserved
Printed in U.S.A.

Materials and specifications are subject to change without notice.
Featured machines in photos may include additional equipment.
See your Caterpillar dealer for available options.

CAT, CATERPILLAR, their respective logos and "Caterpillar Yellow,"
as well as corporate and product identity used herein, are
trademarks of Caterpillar and may not be used without permission.

CATERPILLAR[®]