



4000 Series

4016TWG2

Diesel Engine – Electro Unit

1550 kWm 1500 rev/min



Economic power

- Individual 4 valve cylinder heads give optimised gas flows, while unit fuel injectors ensure ultra fine fuel atomisation and hence controlled rapid combustion for efficiency and economy.
- Commonality of components with other engines in 4000 Series family allows reduced parts stocking levels.

Reliable power

- Developed and tested using latest engineering techniques.
- Piston temperatures are controlled by an advanced gallery jet cooling system.
- All engines are tolerant of a wide range of temperatures without derate.
- Perkins global product support is designed to enhance the customer experience of owning a Perkins powered machine. We deliver this through the quality of our distribution network, extensive global coverage and a range of Perkins supported OEM partnership options. So whether you are an end-user or an equipment manufacturer our engine expertise is essential to your success.

Clean, efficient power

- Exceptional power to weight ratio and compact size for easier transportation and installation.
- Designed to provide excellent service access for ease of maintenance.
- Engines designed to comply with major international standards.
- Low gaseous emissions for cleaner operation.

The Perkins 4000 Series family of 8, 12 and 16 cylinder diesel engines was designed in advance of today's uncompromising demands within the power generation industry and includes superior performance and reliability.

The 4016TWG2 is a turbocharged air to water charge cooled, 16 cylinder vee form diesel engine. Its premium design and specification features provide economic and durable operation as well as exceptional power to weight ratio, improved serviceability, low gaseous emissions, overall performance and reliability essential to the power generation market.

Engine Speed (rev/min)	Type of Operation	Typical Generator Output (Net)		Engine Power			
				Gross		Net	
		kVA	kWe	kWm	bhp	kWm	bhp
1500	Baseload Power	1335	1068	1174	1574	1112	1491
	Prime Power	1688	1350	1468	1969	1406	1885
	Standby (maximum)	1861	1488	1612	2162	1550	2079

The above ratings represent the engine performance capabilities within plus or minus 3% at the reference conditions equivalent to those specified in ISO 8528/1, ISO 3046/1, BS 5514/1.

Ratings conditions: 25°C air inlet temperature, barometer pressure 100 kPa, relative humidity 30%. Please consult your distributor or the factory for ratings in ambient conditions.

Note: For full ratings please refer to Perkins Engines Company Limited. All electrical ratings are based on an average alternator efficiency and a power factor of 0.8.

Fuel specification: BS 2869 Class A1 + A2 or ASTM D975 No 2D.

Rating Definitions

Baseload Power: Power available for continuous full load operation. No overload is permitted.

Prime Power: Power available for variable load with an average load factor not exceeding 80% of the prime power rating in any 24 hour period. Overload of 10% permitted for 1 hour in every 12 hours operation.

Standby (maximum): Power available at variable load in the event of a main power network failure for a maximum of 500 hours per year. No overload is permitted.

4000 Series

4016TWG2

Standard Electro Unit Specification

Air inlet

- Mounted air filters and turbochargers – integral charge coolers

Fuel system

- Unit fuel injectors with lift pump and hand stop control
- Electronic governor to ISO 3046 Part 4 class A1
- Full-flow spin-on fuel oil filters

Lubrication system

- Wet sump with filler and dipstick
- Full-flow spin-on oil filters
- Engine jacket water/lub oil temperature stabiliser

Cooling system

- Twin gear driven circulating pumps
- Two twin thermostats
- Crankshaft pulley for fan drive

Electrical equipment

- 24 volt starter motor and 24 volt/40 amp alternator with integral regulator and DC output
- 24 volt combined high coolant temperature/low oil pressure switch
- Overspeed switch and magnetic pickup
- Turbine inlet temperature shutdown switch
- 24 volt stop solenoid (energised to run)

Flywheel and housing

- Flywheel to SAE J620 size 18
- SAE 00 flywheel housing

Optional Equipment

The following optional equipment is available to make up the specifications to Perkins ElectropaK specification:

Tropical radiator including: Water pipes, clips and hoses

Fan, fan guards and belts

Other optional extra equipment available

Twin heavy duty air cleaner – paper element with pre-cleaner

Changeover lubricating oil filters

Changeover fuel oil filters

Immersion heater with thermostat

Water pipes, clips and hoses for radiator

Air starters

Instrument panel

NB This list is not exhaustive, further options may be available to meet to particular applications on enquiry to Perkins Sales Department

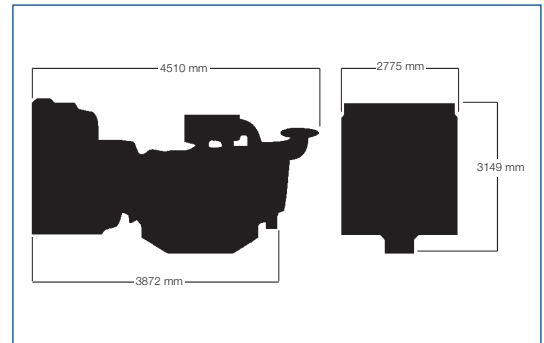

Fuel Consumption (g/kWh)	
Engine Speed	1500 rev/min
At Standby Maximum Rating	210
At Prime Power Rating	208
At Baseload Power Rating	210
At 75% of Prime Power Rating	207
At 50% of Prime Power Rating	209
At 25% of Prime Power Rating	227

General Data

Number of cylinders	16
Cylinder arrangement	60° Vee form
Cycle	4 stroke
Induction system	Turbocharged Air to water charge cooled
Combustion system	Direct injection
Cooling system	Water-cooled
Displacement	61.123 litres
Bore and stroke	160 x 190 mm
Compression ratio	13.6:1
Direction of rotation	Anti-clockwise, viewed from flywheel end
Firing order	1A, 1B, 3A, 3B, 7A, 7B, 5A, 5B, 8A, 8B, 6A, 6B, 2A, 2B, 4A, 4B
Total lubrication system capacity	237.2 litres
Total coolant capacity	Electro Unit 95 litres ElectropaK 295 litres
Length	3289 mm
Width	1547 mm
Height	2128 mm
Total weight (dry)	5940 kg

Final weight and dimensions will depend on completed specification



Perkins Engines Company Limited

Peterborough PE1 5NA

United Kingdom

Telephone +44 (0)1733 583000

Fax +44 (0)1733 582240

www.perkins.com

Distributed by