

1300 Series EDi

1306-E87T

Diesel Engine – Industrial Open Power Unit

140.5 kWm @ 2200 rev/min

Productive power

Hydraulically actuated Electronically controlled Unit Injectors – high pressure injection for true through-the-range performance.

Quick-acting, low inertia turbocharger providing forced induction through helical ports for optimum air/fuel mix and complete combustion.

Clean, efficient power

Constant electronic engine monitoring and management enabling precise fuel metering and injection timing for reliable low temperature starting and superb economy with performance.

Electronically optimised fuel air mixing ensures complete combustion, exhaust virtually free of visible smoke and an emissions capability to match current and future off-highway legislation.

Reliable power

Perkins' outstanding reputation comes from our world-class manufacturing capability. Internationally recognised and customer approved quality procedures ensure unsurpassed reliability.

1300 Series EDi engines incorporate some of the most technologically advanced premium features now available in diesel engines.

Designed to fit

Perkins' industrial open power units offer a complete package with matched cooling system for easy installation and ready to run.

Product Support

- Perkins actively pursues product support excellence by ensuring our distribution network invest in their territory - strengthening relationships and providing more value to you, our customer
- Through an experienced global network of distributors and dealers, fully trained engine experts deliver total service support around the clock, 365 days a year. They have a comprehensive suite of web based tools at their fingertips covering technical information, parts identification and ordering systems, all dedicated to maximising the productivity of your engine
- Throughout the entire life of a Perkins engine, we provide access to genuine OE specification parts and service. We give 100% reassurance that you receive the very best in terms of quality for lowest possible cost .. wherever your Perkins powered machine is operating in the world

The Perkins 1300 EDi Series of variable speed industrial engines is a family of 6 cylinder units with a deserved reputation for providing reliable power and outstanding economy in a wide variety of stationary off-highway applications.

The Perkins 1306-E87T offers a full specification package providing high power and torque from a lightweight compact power unit. Full authority electronic engine management coupled with Hydraulically Actuated Electronic controlled Unit Injectors to provide quiet, clean highly productive power, with outstanding economy.

Performance Data	Net Continuous	Speed (rev/min)
Power Output (kW)	140.5	2220
Power Output (bhp)	188.3	2200
Peak Torque (Nm)	828.0	1600
Peak Torque (lbf ft)	611.0	1600

Note: Radiator package is supplied loose.

Performance and tolerances to ISO 3046/BS5514/DIN6271.

All information in this document is substantially correct at time of printing and may be altered subsequently

Publication No.1623/04/09 Produced in England ©2005 Perkins Engines Company Limited

1300 Series EDi

1306-E87T IOPU

Standard Power Unit Specification

- Mounted air filter
- 12 volt/24 volt alternator
- 12 volt/24 volt starter
- 610 mm pusher fan
- Radiator and fan guard
- Flywheel SAE J620 size 11.5
- Flywheel housing SAE 2
- Hydraulically actuated Electronically controlled Unit Injectors
- Engine mounted electronic governor
- Oil cooler spin on full flow filters
- Wet sump
- Turbocharger with exhaust elbow
- Front engine mounting foot

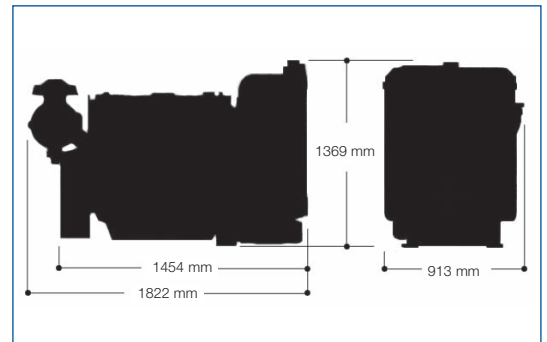

General Data

Bore and stroke	116.6 x 135.9 mm
Number of cylinders	6 in-line vertical
Displacement	8.71 litres
Cycle	4 stroke
Aspiration	Turbocharged
Combustion system	Direct injection
Compression ratio	17.2:1
Firing order	1,5,3,6,2,4
Rotation	Anti-clockwise viewed from flywheel
Governing	Electronic
Cooling system	Thermostatically controlled
Coolant capacity	36.4 litres
Lubricating oil capacity	28.3 litres
Weight (dry)	896.4 kg
Length	1737 mm
Width	913 mm
Height	1369 mm

Overall dimensions and weight will depend on final specification.

Optional Equipment

- Timing case PTO
- Air filter pre-cleaner
- Rear mounting feet
- Tool kit
- User's handbook and parts manual
- Workshop manual

This list is not exhaustive – please consult your Perkins dealer.



Perkins Engines Company Limited

Peterborough PE1 5NA
United Kingdom
Telephone +44 (0)1733 583000
Fax +44 (0)1733 582240
www.perkins.com

All information in this document is substantially correct at time of printing and may be altered subsequently
Publication No. 1623/04/09 Produced in England ©2005 Perkins Engines Company Limited

Distributed by