



1100 Series

1106D-E66TAG2

Diesel Engine - ElectropaK

154 kW @ 1800 rev/min

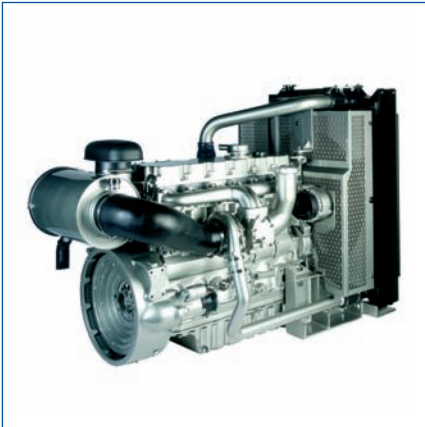

Power to Meet your Needs

Hitting the key power nodes required by the market, the 1106D-E66TAG2 ElectropaK has been developed to provide a clean and cost effective power solution.

State of the Art Design

The 1106D utilises the latest common-rail fuel system technologies with a closely optimised air-management system, which is overseen by the latest generation of electronic engine control. This allows the 1106D range to deliver high power density and excellent fuel economy with low exhaust emissions and minimum heat rejection.

Worldwide Power Solution

The 1106D has been designed to be worldwide fuel tolerant, including kerosene, jet aviation fuel and 5% biofuel (RME). Options are available to meet local market needs.

Product Support

- Perkins actively pursues product support excellence by ensuring our distribution network invest in their territory - strengthening relationships and providing more value to you, our customer
- Through an experienced global network of distributors and dealers, fully trained engine experts deliver total service support around the clock, 365 days a year. They have a comprehensive suite of web based tools at their fingertips covering technical information, parts identification and ordering systems, all dedicated to maximising the productivity of your engine
- Throughout the entire life of a Perkins engine, we provide access to genuine OE specification parts and service. We give 100% reassurance that you receive the very best in terms of quality for lowest possible cost .. wherever your Perkins powered machine is operating in the world

Lower Operating Costs

The 1106D maintains Tier 2 fuel economy. This will allow many customers to keep existing fuel tanks, avoiding the need for costly redesign. Service intervals are set at 500 hours as standard and Perkins provides comprehensive warranty cover for two years (up to 3,000 hours), with three years on major engine components. A low usage warranty package is also available.

Long-term Power Solution

The 1106D-E66TAG ElectropaK range has been designed to fully comply with stringent EPA Tier 3 emissions regulations, providing an emissions compliant power solution for the future.

Certified against the requirements of Tier 3 legislation for non-road mobile machinery, powered by constant speed engines (EPA 40 CFR Part 89 Tier 3).

The 1106D-E66TAG ElectropaKs are the latest addition to Perkins 1100 Series Electric Power line-up. Offering improved power density from a compact package, these ElectropaK's build on Perkins reputation within the Power Generation Industry.

These ultra clean engines are assembled on a new high technology production line. Frequent computerised checks during the production process ensure high build quality is maintained throughout.

Hitting the key power nodes required by the market, the 1106D-E66TAG product line-up consists of three models offering a power solution for both Prime and Standby applications, in 60 Hz territories.

Engine speed (rev/min)	Type of Operation	Typical generator output (net)		Engine power			
				Gross		Net	
		kVA	kWe	kWm	bhp	kWm	bhp
1800	Prime	156	125	144	194	136	183
	Standby (maximum)	175	140	162	217	154	206

The above ratings represent the engine performance capabilities to conditions specified in ISO 8528/5 Derating may be required for conditions outside the test conditions; consult Perkins Engines Company Limited Generator powers are typical and are based on typical alternator efficiencies and a power factor Fuel specification: Consult Perkins Engines Company Limited (various fuel specifications are available) Lubricating oil: multi-grade oil conforming to API-CH4/CJ4 must be used

Rating Definitions

Prime Power: Power available at variable load in lieu of a main power network. Overload of 10% is permitted for 1 hour in every 12 hours' operation Standby (maximum): Power available at variable load in the event of a main power network failure. No overload is permitted

1100 Series

1106D-E66TAG2

Standard ElectropaK Specification

Air inlet

- Mounted air filter and turbocharger

Cooling system

- 27" belt-driven pusher fan and guards
- Radiator (incorporating air-to-air charge cooler + fuel cooler)
- Water pump

Electric system

- 12 volt starter motor
- 12 volt, 100 amp alternator with DC output

Flywheel and housing

- High inertia flywheel
- SAE3 flywheel housing

Fuel system

- Electronic governing (conforms to Class G3 ISO 8528-5)
- Fuel filter

Literature

- Users Handbook

Lubrication system

- Flat-bottomed isolated aluminium sump
- Oil filter

Start aids

- Glow plugs

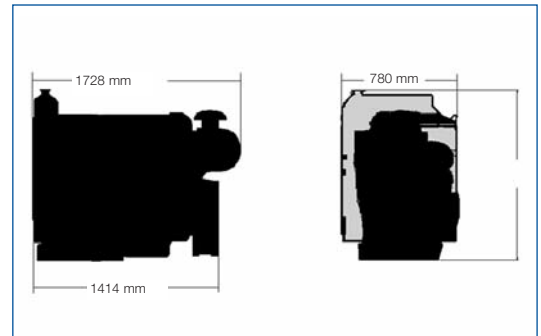

Fuel Consumption		
Engine Speed	1800 rev/min	
	g/kWh	l/hr
Standby	216	41
Prime power	219	38
75% of prime power	232	30
50% of prime power	244	21
25% of prime power	258	11

General Data

Number of cylinders	6 in-line
Bore and stroke	105 mm x 127 mm
Displacement	6.6 litres
Aspiration	Turbocharged air-to-air aftercooling
Cycle	4 stroke
Combustion system	Direct injection
Compression ratio	16.2:1
Rotation	Anti-clockwise viewed on flywheel
Cooling system	Water
Dimensions	Length 1728 mm* Width 780 mm Height 1414 mm
Dry weight	788 kg
Wet weight	822 kg

* Length includes air cleaner
Final weight and dimensions will depend on completed specification



Perkins Engines Company Limited

Peterborough PE1 5NA
United Kingdom
Telephone +44 (0)1733 583000
Fax +44 (0)1733 582240
www.perkins.com

All information in this document is substantially correct at time of printing and may be altered subsequently
Publication No.1796/11/08 Produced in England ©2005 Perkins Engines Company Limited

Distributed by