



■ Technical Information

HCS Grizzly Screen

Performance: 74kw (99Hp)
 Diesel engine: complies with EO emission Regulation 97/68/Ecstep II

All the conveyors have replaceable skirting and feedboot rubber. They are all fitted with internal v-scrapers to protect the tail drums. The transfer and side (fines) conveyor are fitted with rosta tensioned belt scrapers. While the oversize and side (midsize) conveyors are kept clean with octagon beater rollers.

Feeder (Apron)

Width: 870 mm (35")
 Length: 3300 mm (10' 10")
 Construction: Hardox steel apron

Hopper

Volume: 5 m³ (6,6 yd³)
 Foldable wing plates for transportation purposes.

Variable speed conveyor with gearbox (16:1 ratio) and a 315cc hydraulic motor.

Feeder (Belt)

Width: 1200 mm (47")
 Length: 3300 mm (10' 10")
 Belt type: 3 ply conveyor belt

Screenbox

Top Deck: 3650 x 1500 mm (12' x 5"). Available with Hardox Bofar deck, tines, punched plate and mesh.

Variable speed conveyor with gearbox (23:1 ratio) and a 125cc hydraulic motor.

Bottom deck: 3353 x 1500 mm (11' x 5"). Available with cascade fingers and mesh.
 Variable screening angle: 12° to 20°

Oversize Conveyor

Width: 1200 mm (47")
 Length: 5135 mm (16' 10")
 Belt type: 3 ply conveyor belt

Powerunit

Engine: Caterpillar 3054C turbo charged
 Cylinder: 4-cylinder
 Performance: 74 kW (99Hp) at 2200 r.p.m.
 Fuel tank volume: 400 litres (105 USA Gallons)
 Fuel consumption: 18L /hr at 75% continuous load

This conveyor is driven by an 800cc hydraulic motor.

Side conveyor (Midsize)

Width: 800 mm (32")
 Length: 7830 mm (25' 8")
 Belt type: 3-ply C15 chevron conveyor belt

Hydraulics

Triple pump: 36cc/36cc/36cc
 Tandem pump: 23cc/23cc
 Hydraulic tank capacity: 700 litres

Independent variably controlled conveyors driven by a 500cc hydraulic motor

Tracks

Length: 2920 mm (9' 5")
 Width: 500 mm (20")
 Ground pressure: 87 kpa
 Travelling speed: 1.0 km/h

Side conveyor (Fines)

Width: 800 mm (32")
 Length: 7830 mm (25' 8")
 Belt type: 3-ply conveyor belt

Dimensions

Working dimensions:
 Length: 13.000 mm (42' 8")
 Width: 14.300 mm (46' 11")
 Height: 3.365 mm (11')

Independent variably controlled conveyors driven by a 500cc hydraulic motor

Transfer Conveyor

Width: 1200 mm (47")
 Length: 5850 mm (19' 8")
 Belt type: 3-ply conveyor belt

Transport dimensions:
 Length: 14.250 mm (46' 9")
 Width: 3.000 mm (9' 10")
 Height: 3.400 mm (11' 2")

This conveyor is driven by a 500cc hydraulic motor.

Weight: appr. 29 tons (63500 lb)



*** TRANSPORT DIMENSIONS HCS GRIZZLY SCREEN**

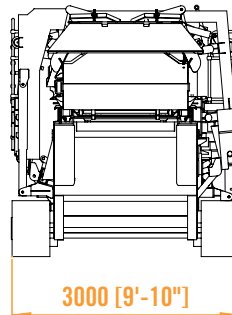
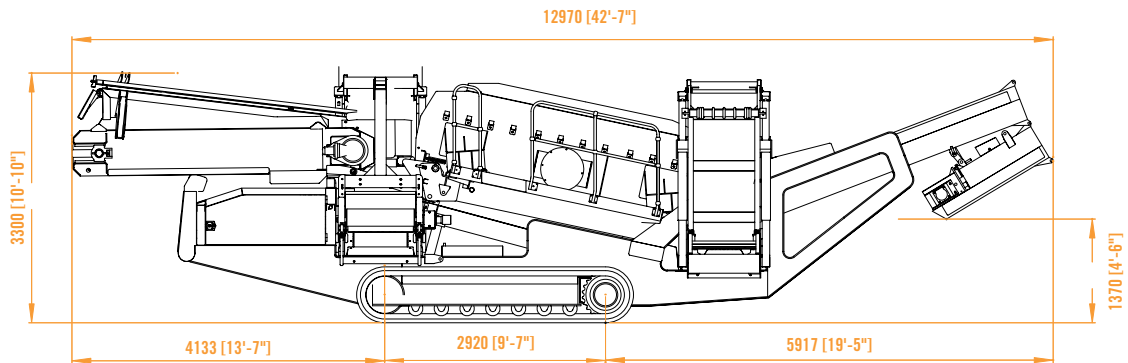

Transport dimensions

29 t (66138 lb) / 14.250 mm x 3.000 mm x 3.400 mm
(46' 9" x 9' 10" x 11' 2") L x W x H